

# ALUCRIU

PERFIS E ACESSÓRIOS  
(48) 3045-6959 / (48) 3443-6550

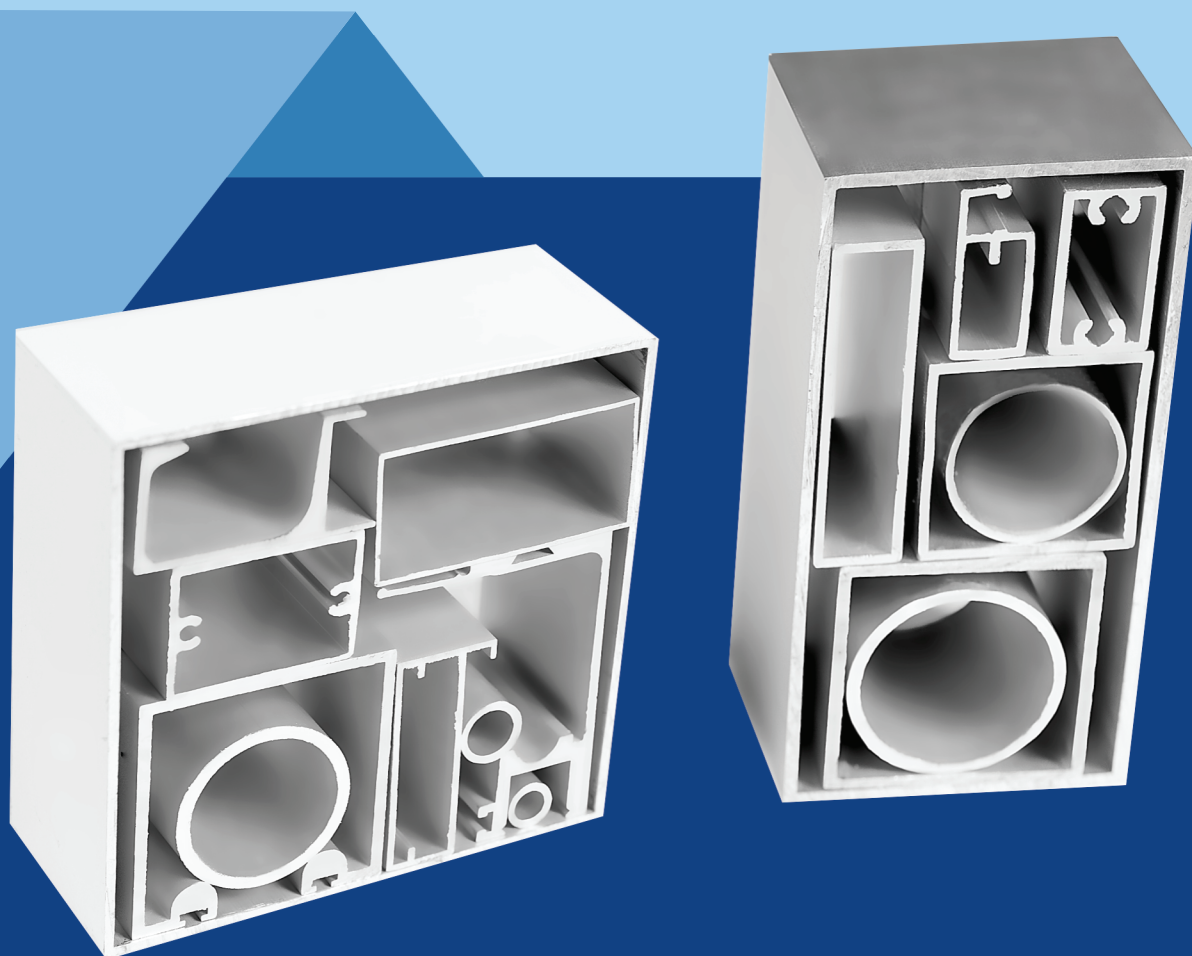

PERFIS



<b>LINHA</b>	<b>Página</b>
<b>PERFIS NORMAIS</b>	<b>04</b>
<b>CONTRAMARCOS/CHUMBADORES/ARREMATES</b>	<b>07</b>
<b>MACHOS E CONEXÕES</b>	<b>08</b>
<b>LINHA 16 BASCULANTE</b>	<b>09</b>
<b>MÓDULO MAX MP</b>	<b>10</b>
<b>LINHA 25</b>	<b>11</b>
<b>MÓDULO PRÁTICO</b>	<b>14</b>
<b>VENEZIANAS</b>	<b>20</b>
<b>VENEZIANAS/SUPREMA</b>	<b>21</b>
<b>SUPREMA</b>	<b>22</b>
<b>SUPREMA ARREDONDADA</b>	<b>32</b>
<b>LINHA INTEGRADA</b>	<b>34</b>
<b>INTEGRADA LEVE</b>	<b>40</b>
<b>LINHA GOLD</b>	<b>45</b>
<b>BOX LINHA LEVE</b>	<b>56</b>
<b>ENVIDRAÇAMENTO DE SACADA</b>	<b>57</b>
<b>GLASING FACHADA ATLANTA</b>	<b>58</b>
<b>VIDRO TEMPERADO</b>	<b>61</b>
<b>VIDRO TEMPERADO 8MM</b>	<b>62</b>
<b>VIDRO TEMPERADO 10 MM</b>	<b>65</b>
<b>PERFIL U</b>	<b>69</b>
<b>CANTONEIRAS</b>	<b>70</b>
<b>TUBO REGULAR</b>	<b>71</b>
<b>TUBO QUADRADO</b>	<b>72</b>
<b>TRILHOS</b>	<b>74</b>
<b>PORTÕES</b>	<b>75</b>
<b>PORTÃO BÚZIOS</b>	<b>76</b>
<b>LAMBRIS</b>	<b>77</b>
<b>PORTÃO/ELEVAÇÃO</b>	<b>78</b>
<b>GRADIL CONVENCIONAL</b>	<b>80</b>
<b>GRADIL PANORAMA</b>	<b>81</b>
<b>LINHA MOVELEIRA</b>	<b>82</b>
<b>PERFIS DIVERSOS</b>	<b>86</b>



CÓDIGO	PESO	PÁG.
20142	2,100	75
25548	1,750	12
A-048	4,200	12
BAC-003	1,000	04
BAC-009	1,200	04
BAC-009L	1,060	04
BAC-013	0,800	04
BAC-015	1,000	04
BAC-021	1,146	04
BAC-025	1,300	04
BAC-061	4,000	04
U-522	0,600	13
BG-035	0,700	10
BG-057	1,020	55
BG-202	0,600	19
BK-005	1,000	82/86
BK-022	0,900	82
BK-035	2,142	82
BK-036	2,000	82
BK-072	0,670	84
BK-073	0,770	84
BK-183	1,550	83
BK-263	1,250	85
BK-408	1,900	83
BK-431	2,750	83
BK-432	2,400	83
BK-497	2,600	84
BK-498	3,600	84
BK-500	1,285	83
BK-503	1,400	83
BK-506	1,100	83
BK-516	2,000	83
BK-529	0,500	83
BK-536	2,400	84
BK-544	1,300	82
BK-545L	1,740	82
BK-546L	1,900	82
BK-552	1,100	85
BK-563	2,400	84
BK-578	2,600	84
BK-615	3,715	84
BX-029	0,500	62
BX-030	1,350	67
BX-041	0,900	64
BX-066	3,600	62
BX-067	1,600	62
BX-084	2,700	56
BX-085	1,100	56
BX-087	0,900	56
BX-090	1,300	56
BX-098	0,850	04/69
BX-099	1,400	67
BX-100	0,950	67
BX-107	0,800	64
BX-121	0,900	56
BX-125	2,900	66
BX-127	0,600	65
BX-128	1,800	65
BX-129	4,100	65
BX-164	2,100	64
CAT-001	0,600	05/70
CAT-001L	0,396	05
CAT-005	0,800	05/70
CAT-005L	0,498	05
CAT-006	0,600	05
CAT-007	0,900	05/70
CAT-016	1,300	05/70
CAT-016L	1,000	05
CAT-019	2,500	05
CAT-019L	2,000	05
CAT-026	3,800	05/70
CAT-027	1,914	05
CAT-029	5,200	05/70
CAT-031	3,250	05
CAT-0719	0,800	05
CG-074	1,600	81
CG-075	3,100	81
CG-077	5,100	81
CG-078	2,500	80
CG-079	2,000	80

CÓDIGO	PESO	PÁG.
CG-083	8,400	81
CL-006	3,300	08
CL-007	2,800	08
CL-008	0,600	08
CL-011	1,000	08
CM-001	1,200	07
CM-002	1,800	07
CM-063	1,100	07
CM-151	1,854	07
CX-071	4,200	80
CX-146	7,000	67/74
CX-170	1,900	86
CX-171	1,300	86
CX-175	5,185	66
CX-175L	4,350	74
D-055	2,870	80
D-069	5,000	75
D-078	3,900	75
D-079	3,020	75
D-079L	2,600	75
D-082	2,000	80
D-083	7,100	79
D-084	17,100	79
D-107	3,950	78
D-108	9,650	78
DS-059	0,900	20
DS-238	3,000	36
E-277	2,800	11
E-364	2,500	75
ES-029	1,000	57
ES-030	3,390	57
ES-032	3,020	57
ES-033	6,025	57
ES-034	3,065	57
ES-035	7,245	57
ES-040	3,355	57
FA-200	11,860	58
FA-201	9,400	58
FA-204	6,353	58
FA-211	6,200	59
FA-228	3,408	60
FA-230	4,850	59
FA-232	3,618	60
FA-235	8,300	58
FA-236	15,815	60
FA-245	4,600	59
FA-294	4,710	59
FC-012	6,100	61
FC-013	1,500	61
FC-014	2,200	61
FC-368	0,780	53
I-105	1,600	13
INT-001	4,060	40
INT-002	4,314	40
INT-003	4,369	40
INT-004	3,238	41
INT-005	4,765	41
INT-006	5,933	41
INT-007	5,574	42
INT-008	3,764	42
INT-009	5,700	43
INT-010	6,970	43
INT-011	5,868	44
LB-004	3,800	76
LB-043	6,130	77
LB-061	4,600	77
LG-002	3,834	46
LG-006	4,062	50
LG-007	7,374	53
LG-015	0,882	55
LG-016	2,028	54
LG-026	0,948	55
LG-027	0,894	55
LG-028	2,724	48
LG-042	7,014	54
LG-043	5,580	54
LG-044	7,464	45
LG-048	5,802	50
LG-049	5,448	50
LG-050	4,866	50

CÓDIGO	PESO	PÁG.
LG-051	5,514	50
LG-055	4,548	53
LG-056	3,858	54
LG-059	1,014	55
LG-062	10,596	46
LG-068	2,400	51
LG-070	13,638	49
LG-072	7,500	48
LG-074	4,600	51
LG-076	4,600	51
LG-077	2,000	51
LG-079	4,620	54
LG-083	2,454	54
LG-085	3,200	52
LG-091	0,900	52
LG-111	0,600	45
LG-116	9,306	47
LG-124	4,638	46
LG-144	6,432	47
LG-145	7,542	47
LG-158	5,256	48
LG-159	6,936	45
LG-160	12,492	49
LG-162	6,444	50
LG-164	0,960	55
LG-166	11,400	38
LG-168	6,600	34
LG-170	5,000	34
LG-235	7,374	53
LG-80034	13,500	38
LG-80035	6,500	37
LG-80041	9,000	37
M-013	1,500	07
MN-001	7,800	34
MN-002	4,020	35
MN-003	6,000	34
MN-007	4,370	36
MN-010	8,100	35
MN-015	5,500	35
MN-027	6,258	36
MN-031	8,320	34
MN-032	11,100	39
MN-039	8,475	39
MN-050	4,200	36
MN-055	2,300	35
MP-056	1,100	10
MP-069	3,800	19
MP-070	3,200	19
MP-300	2,300	14
MP-302	2,700	14
MP-303	2,800	14
MP-305	2,300	14
MP-309	2,600	14
MP-318	2,800	15
MP-321	2,700	14
MP-332	3,600	19
MP-336	2,800	19
MP-347	1,200	07/18
MP-352	1,200	18
MP-354	5,500	18
MP-357	3,900	15
MP-358	3,800	15
MP-360	2,700	16
MP-361	6,500	17
MP-363	3,200	18
MP-366	5,300	16
MP-367	5,400	15
MP-368	4,100	16
MP-369	3,500	16
MP-371	5,400	17
MP-378	2,200	17
MP-397	2,500	18
MP-404	4,200	15
MP-409	3,600	17
P-140	2,600	12
P-145	3,000	13
P-146	2,500	11
P-147	1,900	11
P-153	2,900	11
P-274	5,800	11



CÓDIGO	PESO	PÁG.
P-318	3,600	12
P-319	4,500	13
P-412	3,400	13
P-414	4,200	13
P-506	4,200	12
P-507	4,000	12
PC-010	5,900	76
PC-010L	4,550	76
PEU-002	0,900	04
PEU-002L	0,588	04
PEU-015	1,200	04/84
PEU-028	0,900	04/69
PEU-047	2,300	04/75
PEU-289	0,450	04
PEU-315	1,000	04/69
PEU-329	1,300	04/69
PEU-641	1,000	04
PDV-079	0,890	75
PLD-001	0,800	09
PLD-002	1,000	09
PLD-003	1,300	09
PLD-004	0,900	09
PLD-005	1,800	09
PLD-006	1,100	09
PLK-007	1,000	63
PLK-012	3,700	66
PLK-017	1,600	66
PLK-014	0,960	67
PLK-023	1,200	62
PLK-025	2,100	04/69
PLK-029	0,900	66
PLK-034	1,340	66
PLK-037	0,900	62
PLK-038	2,400	64
PLK-043	0,500	63
PLK-046	0,910	63
PLK-047	1,400	64
PLK-053	7,600	65
PLK-057	2,100	66
PLK-058	1,460	63
PLK-440	1,250	64
PLK-516	11,750	68
PLK-518	2,738	66
PLK-525	3,180	63
PLK-541	5,850	68
PLS-053	1,650	25
PMQ-052	1,800	10
PMQ-053	2,000	10
PMQ-055	3,000	10
PMQ-056	2,000	10
PMQ-057	2,700	10
PMQ-064	2,400	10
PVZ-027	1,800	20
SA-018	0,643	32
SA-25500	3,195	32
SA-25501	2,750	32
SA-25502	2,923	32
SA-25503	3,152	32
SA-25504	3,421	32
SA-25504	4,332	32
SA-25505	3,421	33
SA-25505	4,332	33
SA-25507	2,361	33
SA-25791	3,504	33
SA-25792	4,283	33
SA-25793	5,123	33
SU-001	4,000	22
SU-002	4,000	22
SU-003	3,000	22
SU-004	3,000	23
SU-005	6,000	23
SU-006	6,400	23
SU-007	2,300	23
SU-008	1,400	24
SU-009	4,500	24
SU-010	6,100	24
SU-011	5,700	24
SU-012	3,400	25
SU-013	4,200	25
SU-014	3,900	25

CÓDIGO	PESO	PÁG.
SU-039	3,100	26
SU-040	2,900	26
SU-041	3,000	26
SU-042	3,400	26
SU-043	5,100	27
SU-047	5,800	27
SU-049	5,400	27
SU-053	3,000	27
SU-068	3,200	21
SU-069	3,400	28
SU-070	3,200	28
SU-079	2,100	28
SU-080	2,100	28
SU-081	2,100	28
SU-082	2,300	29
SU-083	0,900	29
SU-085	3,100	29
SU-086	3,100	29
SU-088	1,900	29
SU-102	0,700	26
SU-103	0,800	29
SU-108	0,900	21
SU-111	3,900	31
SU-187	2,850	26
SU-192	3,100	30
SU-200	2,100	28
SU-203	0,800	21
SU-225	6,000	30
SU-227	3,300	30
SU-228	3,900	31
SU-230	5,500	31
SU-242	4,200	22
SU-243	4,000	22
SU-245	3,850	22
SU-279	3,371	31
SU-280	4,300	30
SU-291	1,450	25
TUG-004L	1,806	05
TUG-014	4,390	05/71
TUG-019L	8,700	05
TUG-022	7,668	05/71
TUG-022L	6,400	05/71
TUG-040	2,400	05
TUG-040L	1,938	05
TUG-050	9,980	05
TUG-124	1,200	05
TUG-124L	0,900	05
TUQ-009L	1,450	06/73
TUQ-014	3,800	06/73
TUQ-014L	1,965	06/73
TUQ-015	3,000	06/73
TUQ-034	16,100	06
TUQ-051L	3,900	06/73
TUQ-059	2,670	06/73
TUQ-060	11,700	06/72
TUQ-061	7,300	06/72
TUR-002	0,670	06
TUR-002L	0,575	06
TUR-005	0,900	06
TUR-005L	0,780	06
TUR-014	1,100	06
TUR-014L	0,800	06
TUR-018	0,900	06
TUR-018L	0,800	06
TUR-039	1,300	06/82
TUR-047	2,450	06
TUR-058	4,000	06
TUR-070	3,028	06/78
TUR-070L	2,515	06
TUR-097	3,200	06
TUR-311L	4,400	06
U-522	0,600	13
U-990	3,600	74
U-1098	3,000	74
U-1098L	2,560	74
U-1108	1,900	67
US-622	1,800	21
VZ-024	1,400	20
VZ-024US	1,400	20
VZ-023	1,500	20

CÓDIGO	PESO	PÁG.
VZ-023US	1,500	20
VZ-074	1,800	21
Y-107	1,400	75
Y-126	2,100	11
Y-335	3,800	77
Y-429	3,800	77



## PERFIL U ABAS IGUAIS

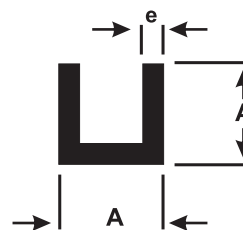

CÓDIGO	MILÍMETROS		POLEGADAS		PESO ( Kg/br )
	A	e	A	e	
PEU-289	9,52	1,00	3/8	-	0,450
PEU-002L	12,70	1,00	1/2	-	0,588
PEU-002	12,70	1,58	5/8	1/16	0,900
PEU-028	15,87	1,20	1/2	-	0,900

## PERFIL U ABAS DESIGUAIS

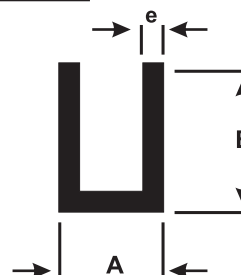

CÓDIGO	MILÍMETROS			POLEGADAS			PESO ( Kg/br )
	A	B	e	A	B	e	
PEU-315	13,80	24,80	1,00	-	-	-	1,000
PEU-329	15,00	25,00	1,30	-	-	-	1,300
PEU-015	19,05	12,70	1,70	-	-	-	1,200
PEU-641	19,70	12,70	1,40				1,000
PEU-047	29,00	35,00	1,30				2,300
BX-098	13,80	20,00	1,10				0,850
PLK-025	14,40	48,00	1,30				2,100

## BARRA CHATA



CÓDIGO	MILÍMETROS		POLEGADAS		PESO ( Kg/br )
	A	B	A	B	
BAC-003	12,70	4,76	1/2	3/16	1,000
BAC-009	15,87	4,76	5/8	3/16	1,200
BAC-009L	15,87	4,10	5/8	-	1,060
BAC-013	15,87	3,18	5/8	1/8	0,800
BAC-015	19,05	3,18	3/4	1/8	1,000
BAC-021	22,22	3,18	7/8	1/8	1,146
BAC-025	25,40	3,18	1	1/8	1,300
BAC-061	50,80	4,76	2	3/16	4,000



## CANTONEIRA

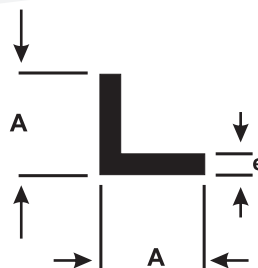

CÓDIGO	MILÍMETROS		POLEGADAS		PESO ( Kg/br )
	A	e	A	e	
CAT-001	12,70	1,58	1/2	1/16	0,600
CAT-001L	12,70	1,00	1/2	-	0,396
CAT-005	15,87	1,58	5/8	1/16	0,800
CAT-005L	15,57	1,00	5/8	-	0,498
CAT-006	19,05	1,00	3/4	-	0,600
CAT-007	19,05	1,58	3/4	1/16	0,900
CAT-016	25,40	1,58	1	1/16	1,300
CAT-016L	25,40	1,20	1	-	1,000
CAT-019	25,40	3,18	1	1/8	2,500
CAT-019L	25,40	2,45	1	-	2,000
CAT-0719	25,40	1,00	1.1/2	-	0,800
CAT-026	38,10	3,18	1.1/2	1/8	3,800
CAT-027	38,10	1,58	1	1/16	1,914
CAT-029	50,80	3,18	2	1/8	5,200
CAT-031	50,80	2,00	2	-	3,250

## TUBO RETANGULAR

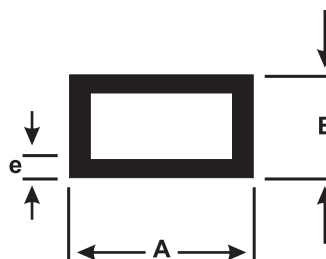

CÓDIGO	MILÍMETROS			POLEGADAS			PESO ( Kg/br )
	A	B	e	A	B	e	
TUG-124L	25,40	12,70	0,80	1"	1/2"	-	0,900
TUG-124	25,40	12,70	1,00	1"	1/2"	-	1,200
TUG-004L	50,80	12,70	0,90	2"	1/2"	-	1,806
TUG-040L	50,80	25,40	0,80	2"	1"	-	1,938
TUG-040	50,80	25,40	1,00	2"	1"	-	2,400
TUG-014	76,20	38,10	1,20	3"	1.1/2"	-	4,390
TUG-019L	101,60	50,80	1,78	4"	2"	-	8,700
TUG-022	101,60	50,80	1,58	4"	2"	1/16	7,668
TUG-022L	101,60	50,80	1,30	4"	2"	-	6,400
TUG-050	152,40	50,80	1,58	6"	2"	1/16	9,980



**TUBO QUADRADO**

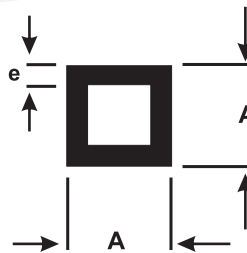

CÓDIGO	MILÍMETROS		POLEGADAS		PESO ( Kg/br )
	A	e	A	e	
TUQ-009L	25,40	0,90	1	-	1,450
TUQ-059	31,75	1,35	1.1/4	-	2,670
TUQ-014	38,10	1,58	1.1/2	1/16	3,800
TUQ-014L	38,10	0,80	1.1/2	-	1,965
TUQ-015	38,10	1,20	1.1/2	-	3,000
TUQ-051L	50,80	1,20	2	-	3,900
TUQ-061	90,00	1,30	-	-	7,300
TUQ-060	101,60	1,80	4	-	11,700
TUQ-034	101,60	2,50	4	-	16,100

**TUBO REDONDO**

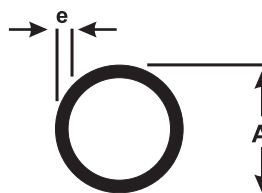

CÓDIGO	MILÍMETROS		POLEGADAS		PESO ( Kg/br )
	A	e	A	e	
TUR-002	9,52	1,50			0,670
TUR-002L	9,52	1,35		1/16	0,575
TUR-005	12,70	1,58	1/2		0,900
TUR-005L	12,70	1,35	1/2		0,780
TUR-014L	15,87	1,00	5/8		0,800
TUR-014	15,87	1,58	5/8	1/16	1,100
TUR-018L	19,05	0,80	3/4		0,800
TUR-018	19,05	1,00	3/4		0,900
TUR-039	25,4	1,00	1		1,300
TUR-047	31,75	1,58	1.1/4	1/16	2,450
TUR-058	33,30	2,50	5/16		4,000
TUR-070	38,10	1,58	1.1/2	1/16	3,028
TUR-70L	38,10	1,30	1.1/2		2,515
TUR-097	50,80	1,30	2		3,200
TUR-311L	76,20	1,15	3		4,400



**CM-151**

1,854 kg /br

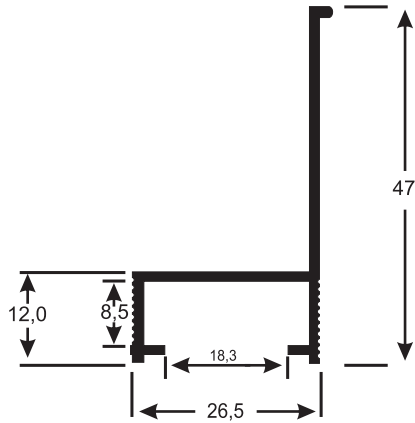

**CM-063**

1,100 kg /br

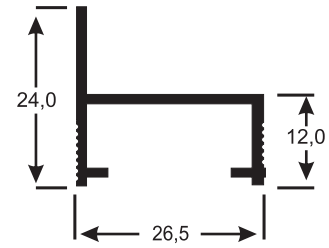

**CM-001**

1,200 kg /br

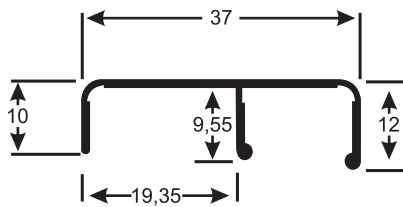

**CM-002**

1,800 kg /br

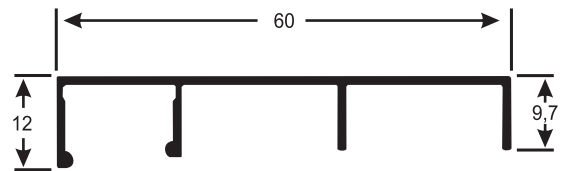

**M-013**

1,500 kg /br

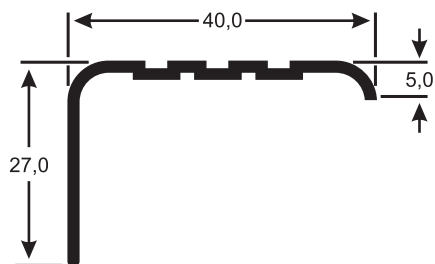

**MP-347**

1,200 kg /br

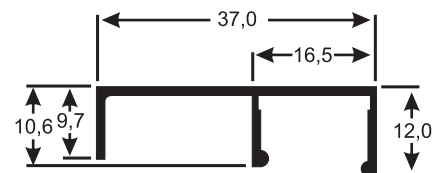



## CL-006

3,300 kg /br  
CANTONEIRA

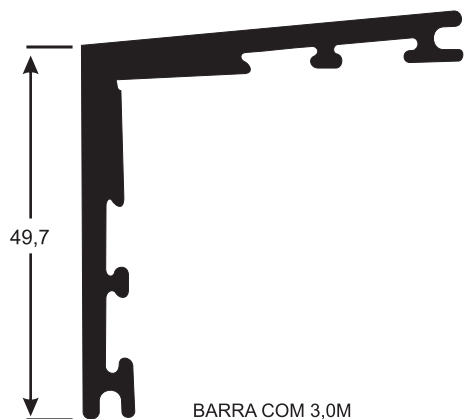

## CL-011

1,000 kg /br  
CUNHA

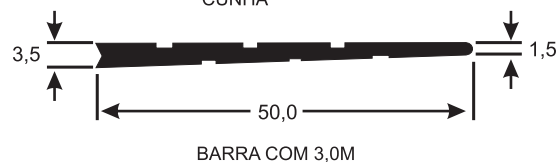

## CL-007

2,800 kg /br  
CANTONEIRA

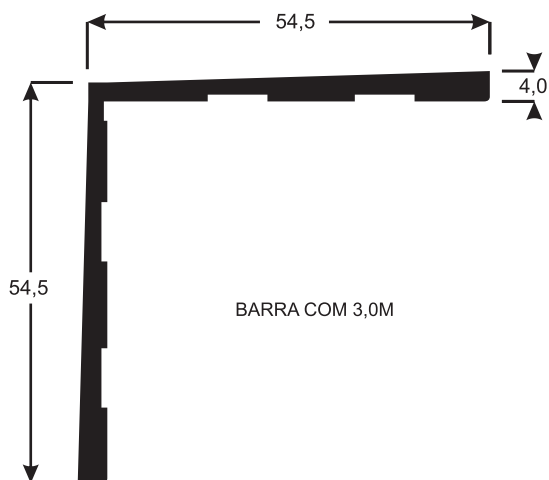

## CL-008

0,600 kg /br  
CUNHA

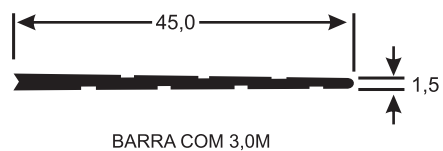



### PLD-001

0,800 kg /br

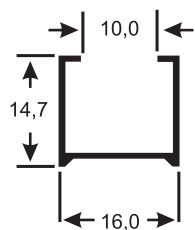

### PLD-002

1,000 kg /br

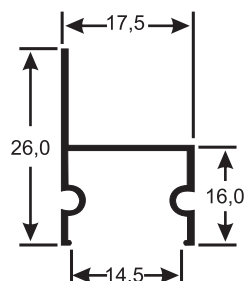

### PLD-003

1,300 kg /br

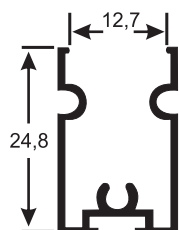

### PLD-004

0,900 kg /br

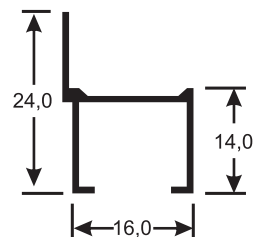

### PLD-005

1,800 kg /br

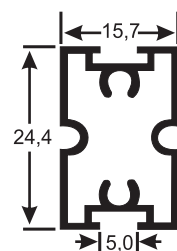

### PLD-006

1,100 kg /br

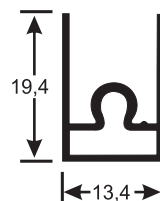



## PMQ-052 = 25 311

1,800 kg /br  
MARCO

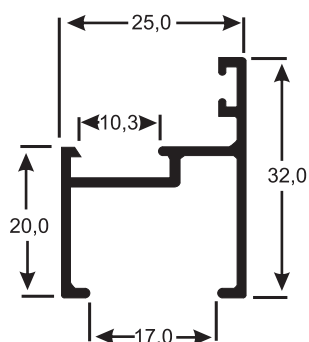

## PMQ-053 = 25 312

2,000 kg /br  
MARCO

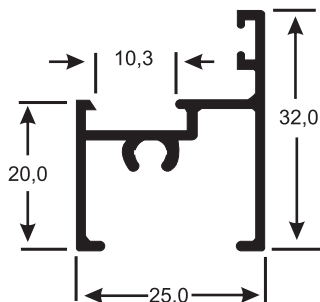

## PMQ-056 = 25 301

2,000 kg /br  
TRAVESSA FOLHA

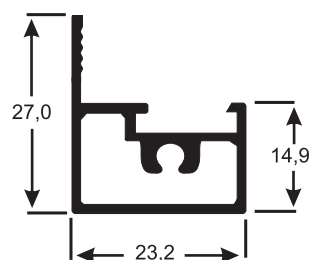

## PMQ-055 = MM 376

3,000 kg /br  
COLUNA / MARCO

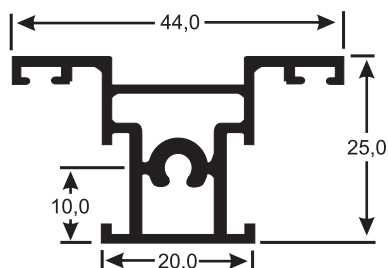

## PMQ-057 = 25 308

2,700 kg /br  
COLUNA / MARCO

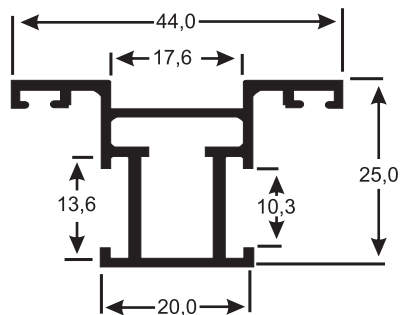

## PMQ-064 = MM 375

2,400 kg /br  
MONTANTE / TRAVESSA FOLHA

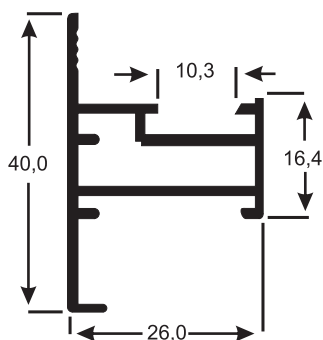

## BG-035

0,700 kg /br  
BAGUETE

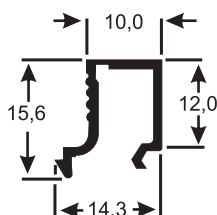

## MP-056

1,100 kg /br  
PINGADEIRA / MARCO

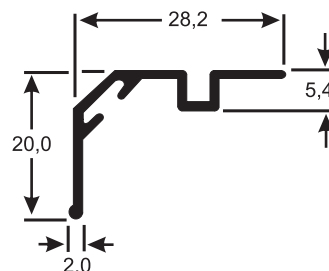



**P-147 = 25 001**

1,900 kg /br  
TRAVESSA DA FOLHA

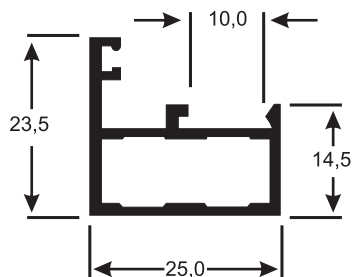

**Y-126 = 25 002**

2,100 kg /br  
MARCO

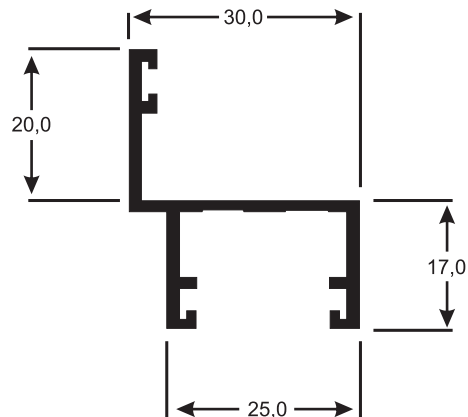

**P-146 = 25 005**

2,500 kg /br  
MONTANTE / TRAVESSA DA FOLHA

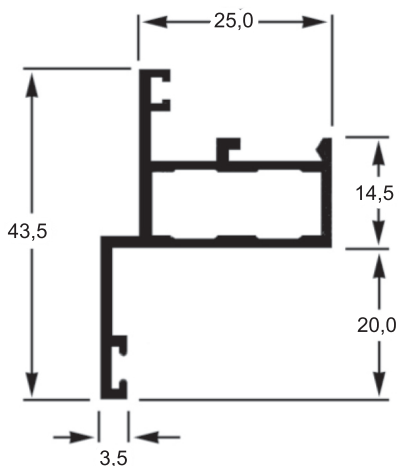

**P-274 = FC 070**

5,800 kg /br  
CÓLUNA

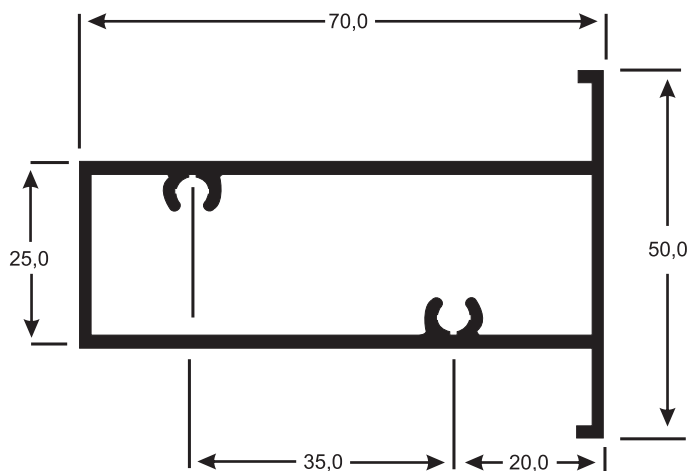

**E-277 = 25 514**

2,800 kg /br  
MARCO LATERAL / CORRER

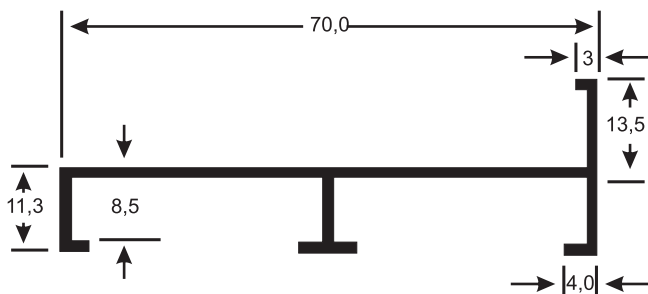

**P-153 = 25 026**

2,900 kg /br  
TRAVESSA DA FOLHA DO MARCO

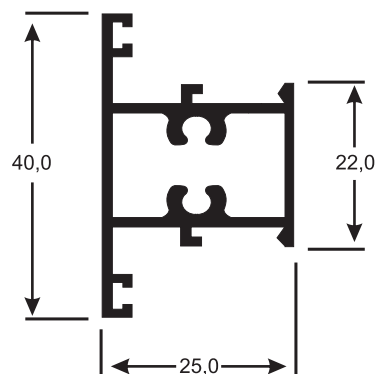



**25548**

1,750 kg /br

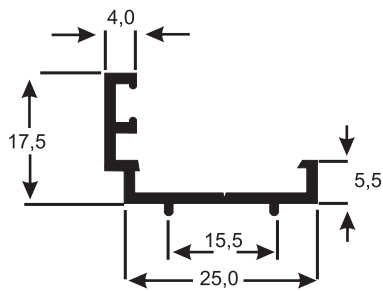

**P-140 = 25 016**

2,600 kg /br

MONTANTE DA FOLHA

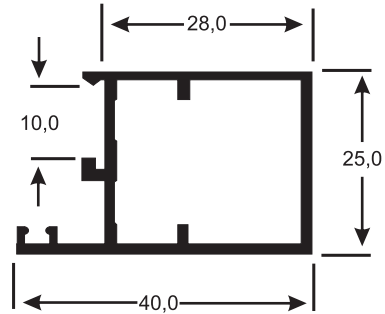

**A-048 = 25 502**

4,200 kg /br

TRAVESSA FOLHA PORTA SUPERIOR

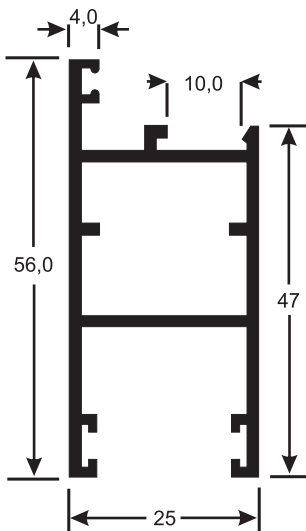

**P-318 = 25 504**

3,600 kg /br

MONTANTE DA FOLHA DA PORTA

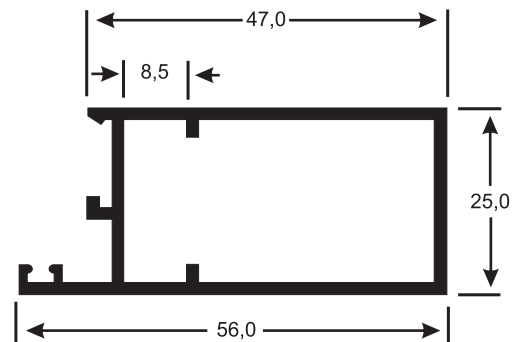

**P-506 = 25 506**

4,200 kg /br

MONTANTE MÃO DE AMIGO PORTA

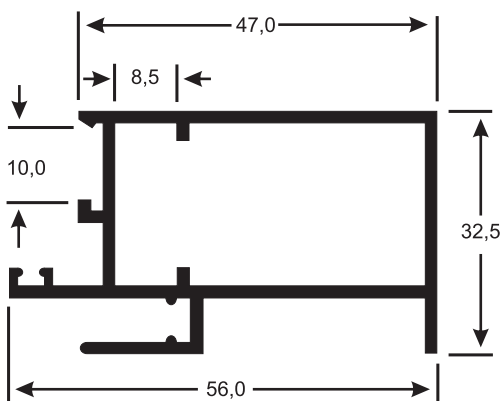

BARRA COM 6,0M

**P-507 = 25 507**

4,000 kg /br

MONTANTE MÃO DE AMIGO PORTA

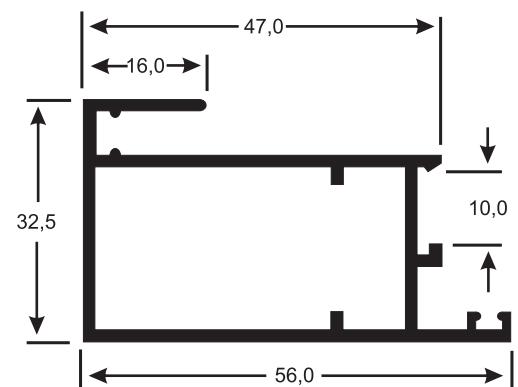

BARRA COM 6,0M



**P-145 = 25 018**

3,000 kg /br  
MONTANTE TRAVESSA FOLHA

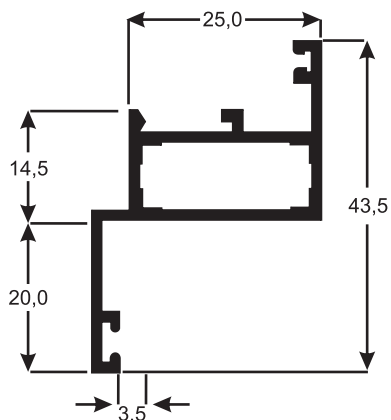

**P-319 = 25 508**

4,500 kg /br  
TRAVESSA CENTRAL FOLHA

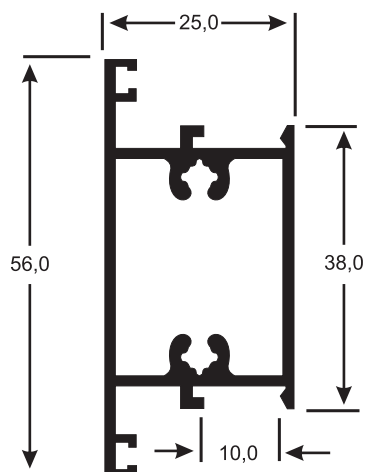

**P-412 = 25 540**

3,400 kg /br  
MARCO

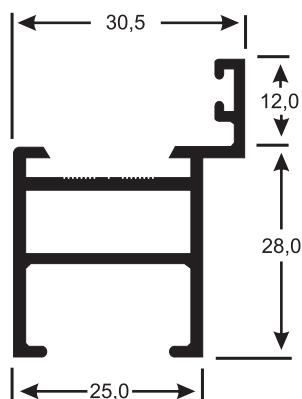

**P-414 = 25 542**

4,200 kg /br  
MONTANTE DA FOLHA

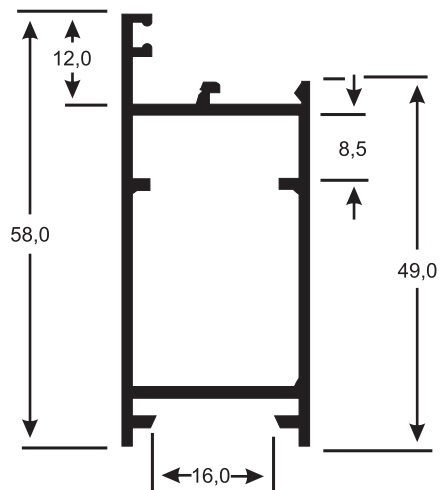

**I-105**

1,600 kg /br  
REMATE LATERAL

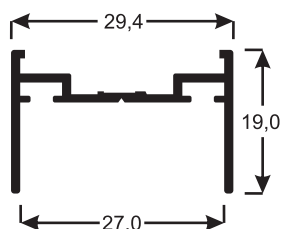

**U-522 = BG 001**

0,600 kg /br

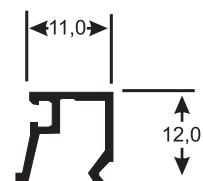



## MP-300

2,300 kg /br  
MONTANTE DE FOLHA

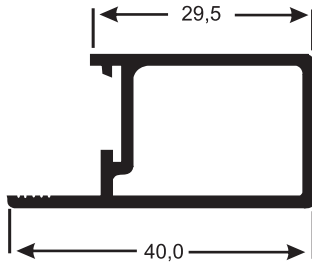

## MP-302

2,700 kg /br  
MONTANTE MÃO DE AMIGO

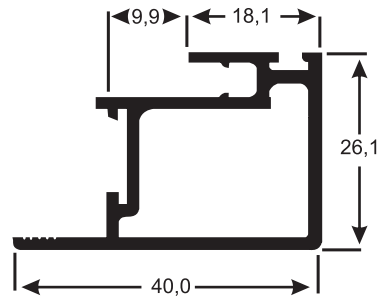

## MP-303

2,800 kg /br  
MONTANTE MÃO DE AMIGO COM VENEZIANA

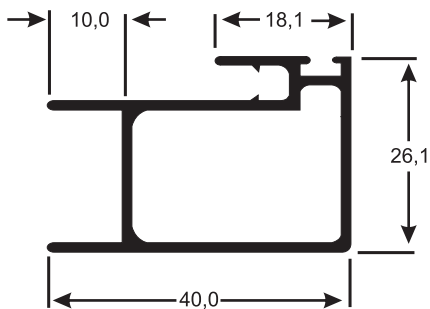

## MP-305

2,300 kg /br  
MONTANTE DA FOLHA COM VENEZIANA

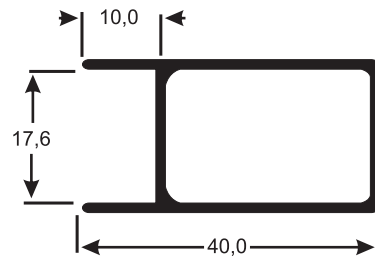

## MP-309

2,600 kg /br  
TRAVESSA DA FOLHA

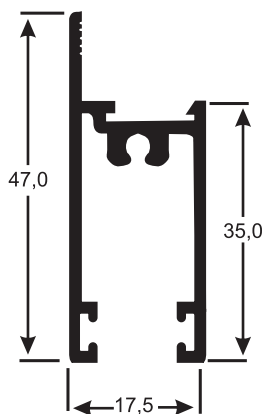

## MP-321

2,700 kg /br  
MONTANTE MÃO DE AMIGO

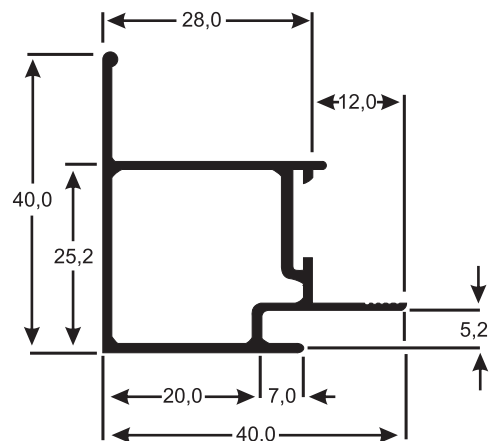



## MP-404

4,200 kg /br

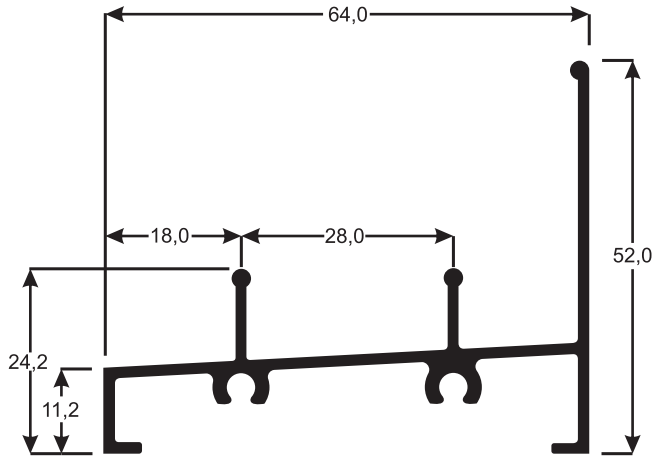

## MP-357

3,900 kg /br

MARCO SUPERIOR CORRER

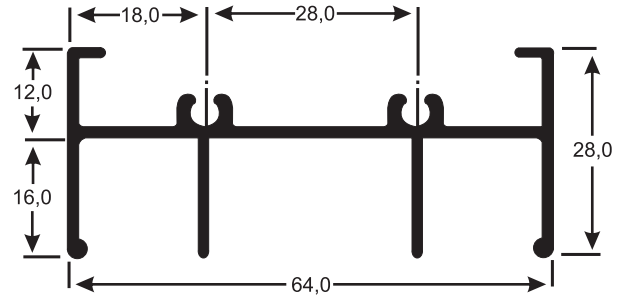

## MP-367

5,400 kg /br

TRILHO INFERIOR JANELA

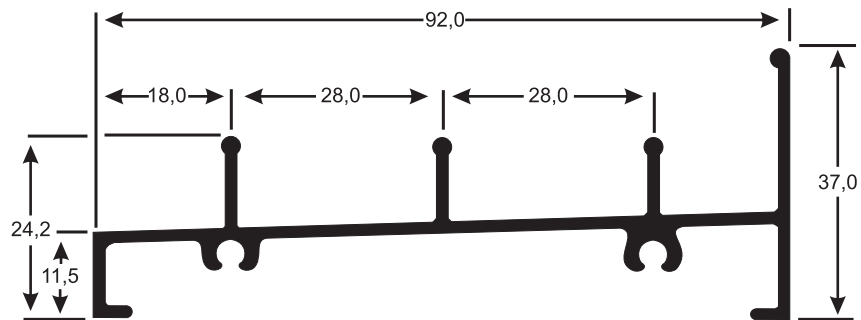

## MP-358

3,800 kg /br

TRILHO INFERIOR JANELA DUAS FOLHAS

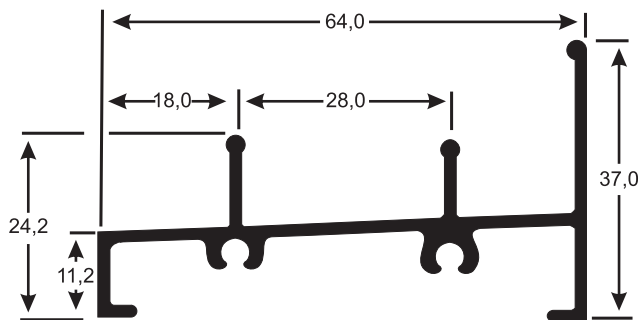

## MP-318

2,800 kg /br

MONTANTE COM REMATE

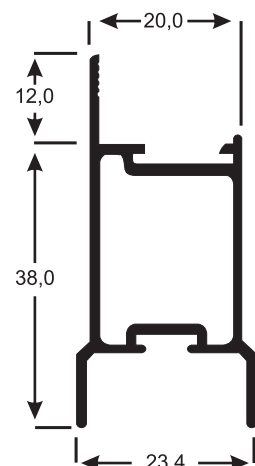



## MP-360

2,700 kg /br

MARCO LATERAL / CORRER

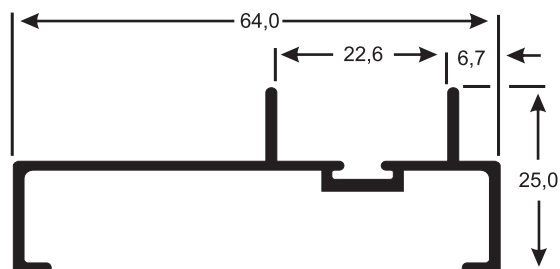

## MP-366

5,300 kg /br

MARCO SUPERIOR CORRER

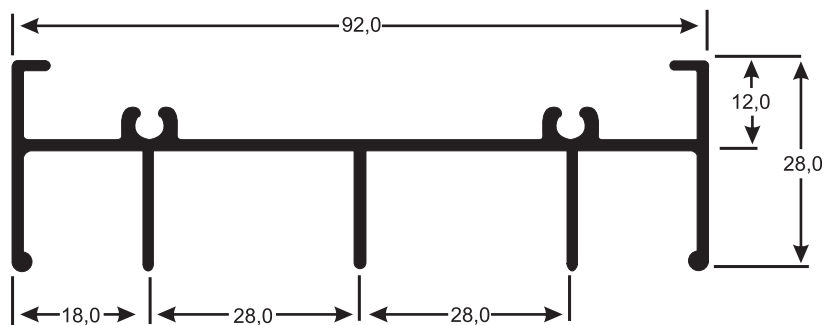

## MP-368

4,100 kg /br

MARCO LATERAL JANELA 3 FOLHAS

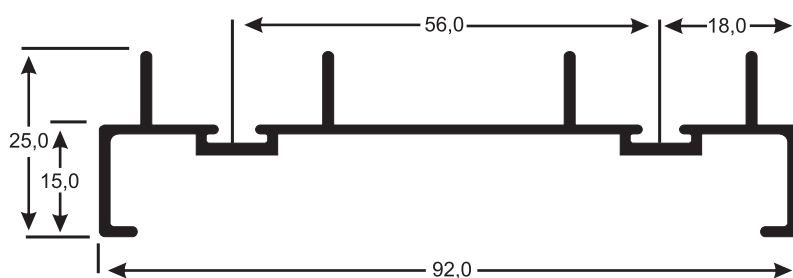

## MP-369

3,500 kg /br

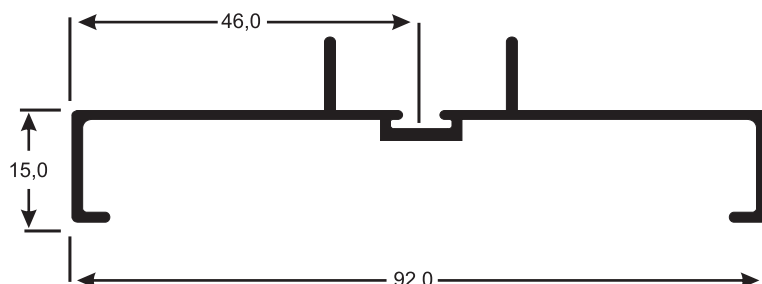



## MP-361

6,500 kg /br

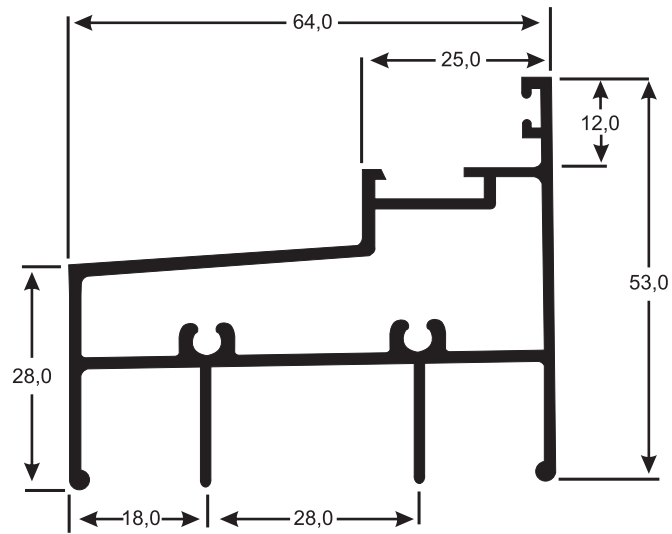

## MP-371

5,400 kg /br

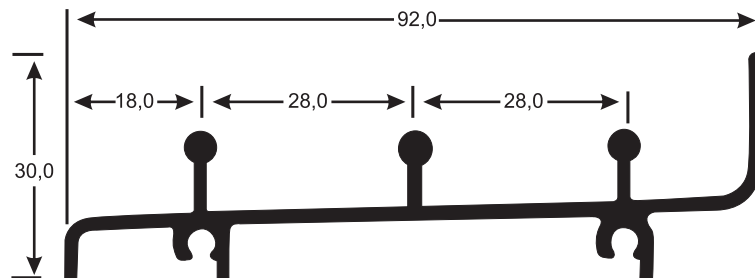

## MP-378

2,200 kg /br

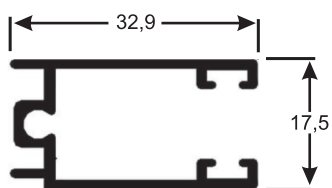

## MP-409

3,600 kg /br

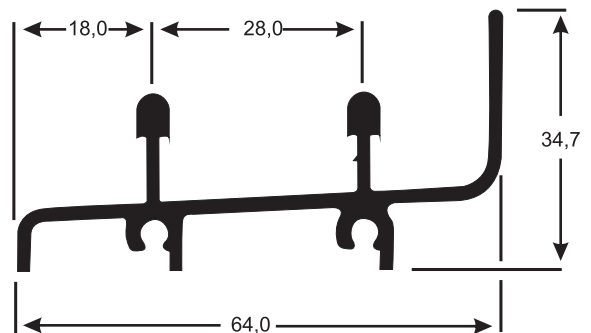



## MP-347

1,200 kg /br  
REMATE OU VISTA

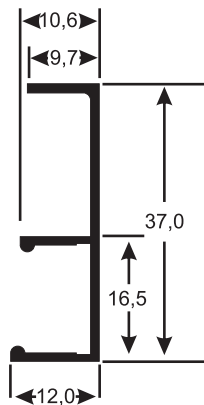

## MP-352

1,200 kg /br  
REMATE LATERAL

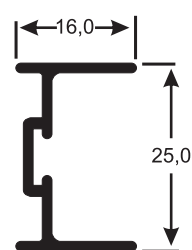

## MP-363

3,200 kg /br  
MARCO BANDEIRA PEITORIL

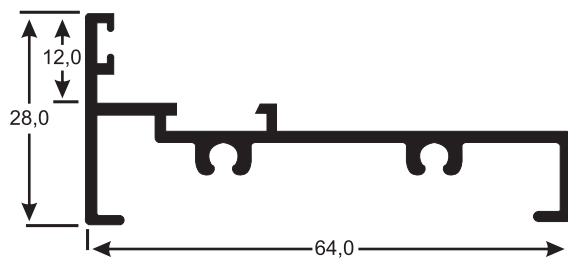

## MP-397

2,500 kg /br  
MARCO DA BANDEIRA PEITORIL/CORRER

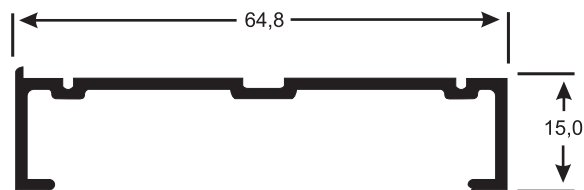

## MP-354

5,500 kg /br  
TRAVESSA INFERIOR DA FOLHA

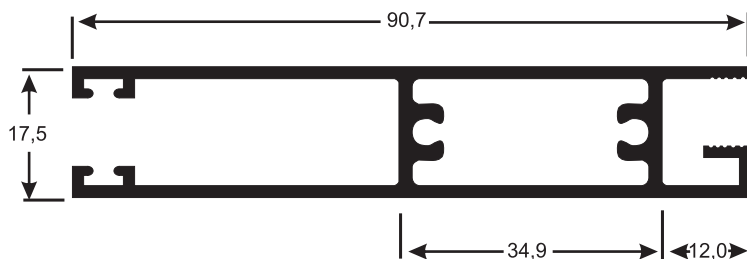



## MP-332

3,600 kg /br  
TRAVESSA CENTRAL DA FOLHA

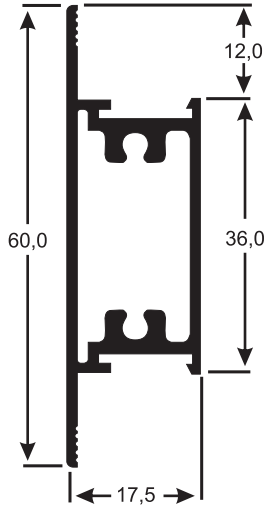

## MP-336

2,800 kg /br  
MONTANTE DA FOLHA PORTA

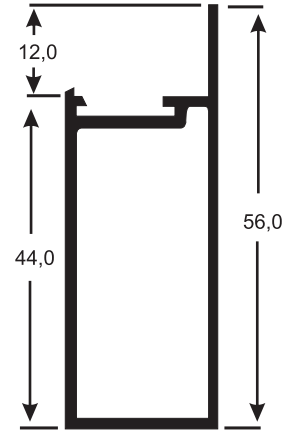

## BG-202

0,600 kg /br  
BAGUETE

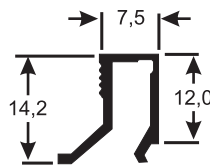

## MP-069

3,800 kg /br  
MONTANTE MÃO DE AMIGO PORTA

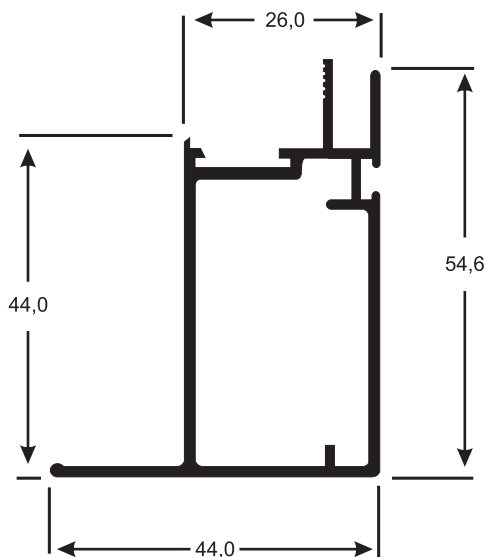

## MP-070

3,200 kg /br  
MONTANTE MÃO DE AMIGO PORTA

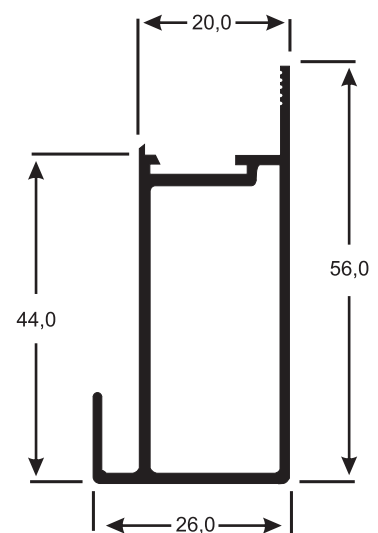



**VZ-024**  
1,400 kg /br  
VENEZIANA

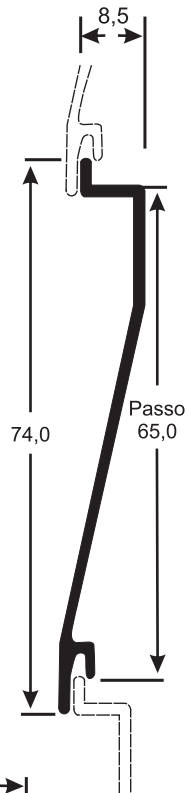

**VZ-024 US**  
1,400 kg /br  
VENEZIANA VENTILADA

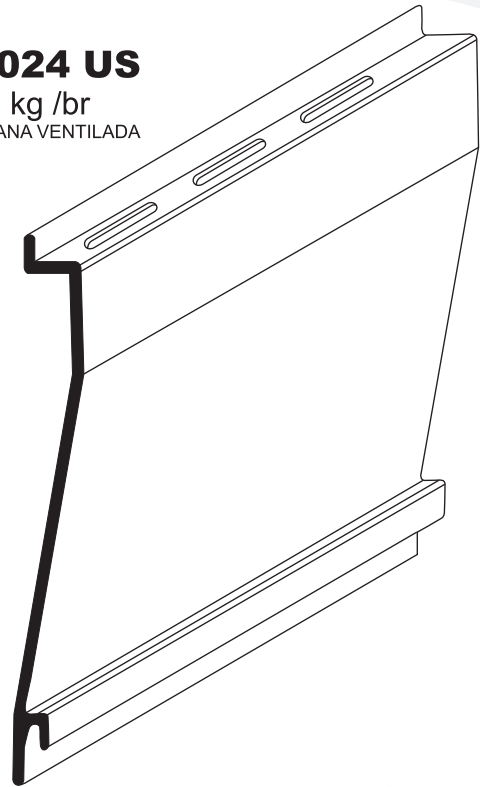

**VZ-023**  
1,500 kg /br  
VENEZIANA

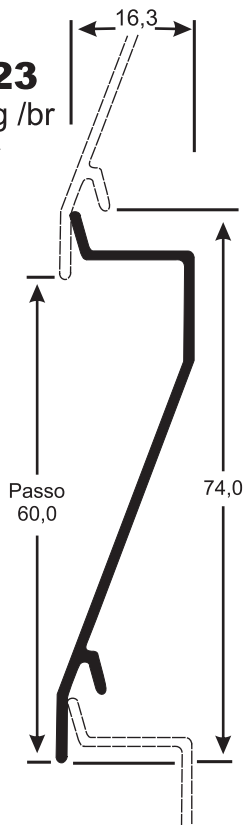

**VZ-023 US**  
1,500 kg /br  
VENEZIANA VENTILADA

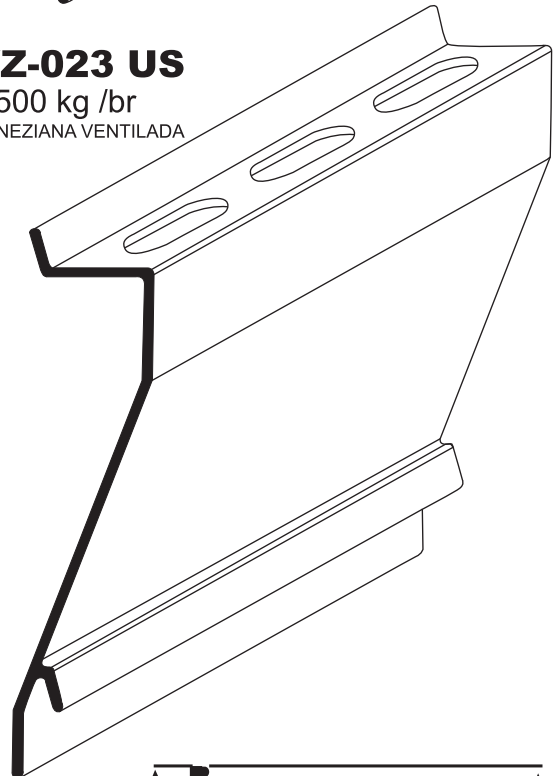

**DS-059 = DS-036**  
0,900 kg /br

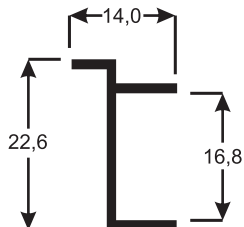

**PVZ-027**  
1,800 kg /br

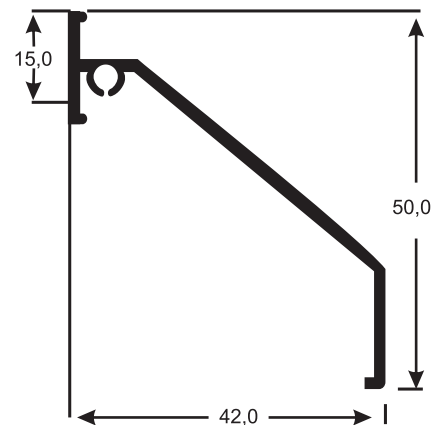



## VZ-074

1,800 kg /br  
VENEZIANA SUPREMA

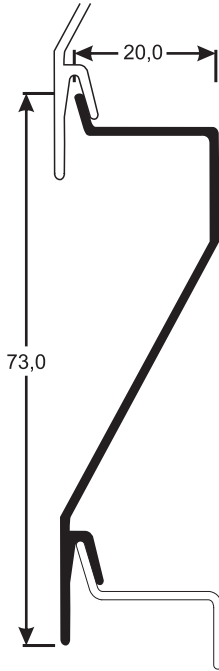

## US-622

1,800 kg /br  
VENEZIANA VENTILADA/SUPREMA

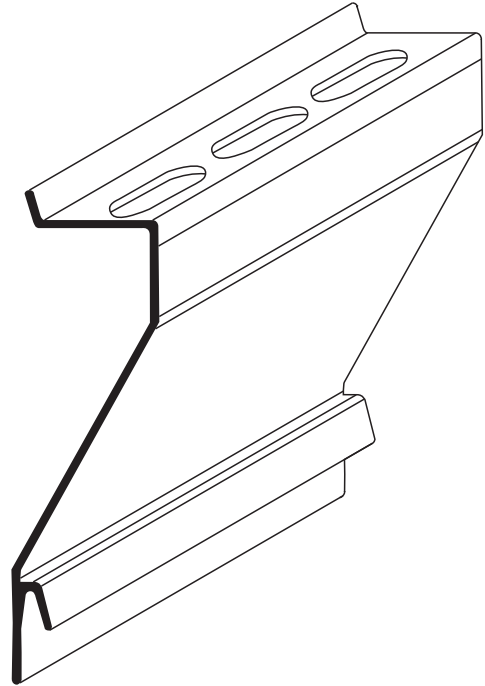

## SU-108

0,900 kg /br  
PORTA PALHETA SUPREMA

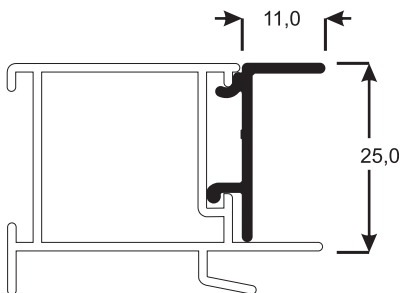

## SU-068

3,200 kg /br  
MONTANTE DA FOLHA VENEZIANA

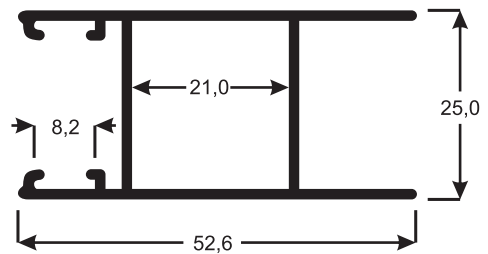

## SU-203

0,800 kg /br  
ACOPLADOR VENEZIANA/SUPREMA

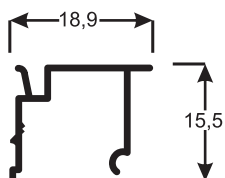



**SU-001**

4,000 kg /br  
MARCO SUPERIOR / CORRER 2

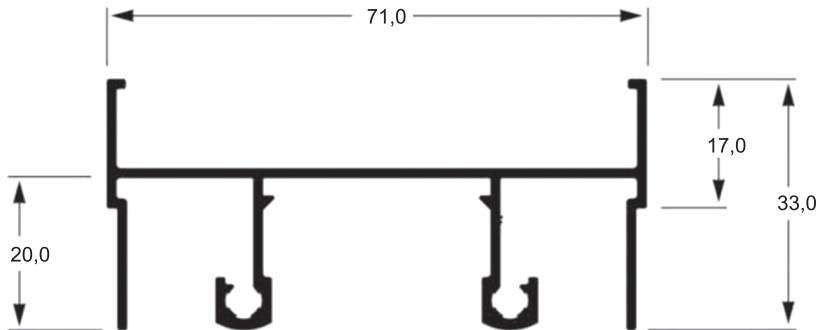

**SU-242**

4,200 kg /br

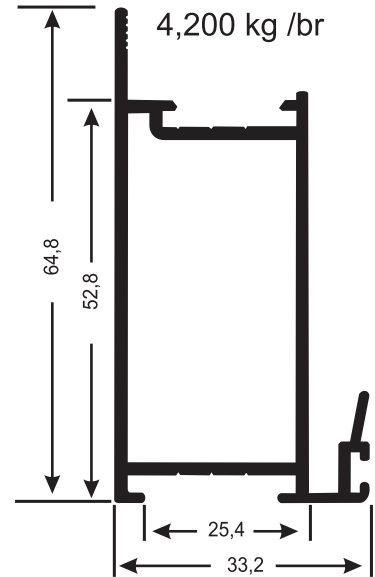

**SU-002**

4,000 kg /br  
MARCO INFERIOR / CORRER 2

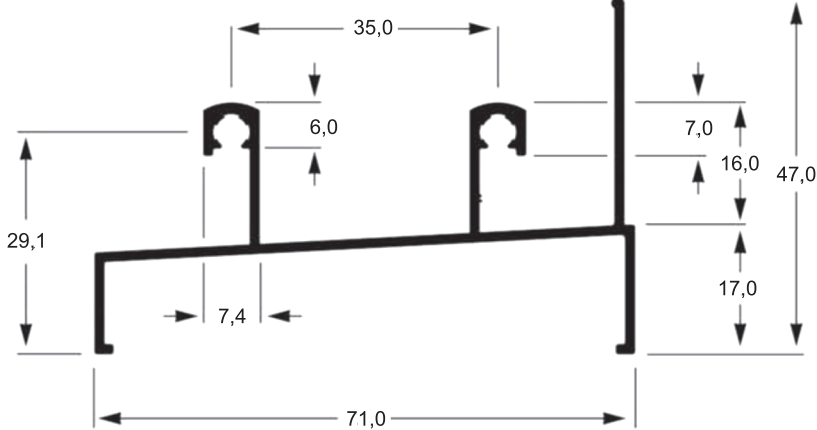

**SU-243**

4,000 kg /br

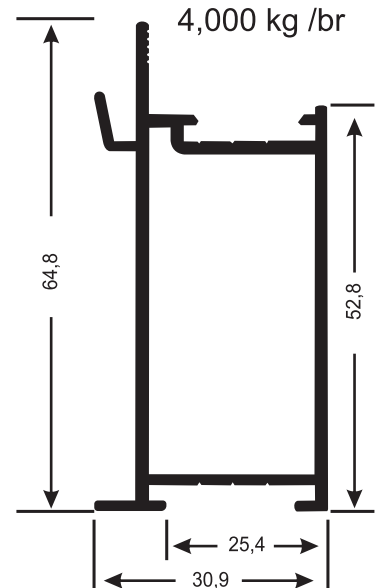

**SU-003**

3,000 kg /br  
MARCO LATERAL / CORRER 2

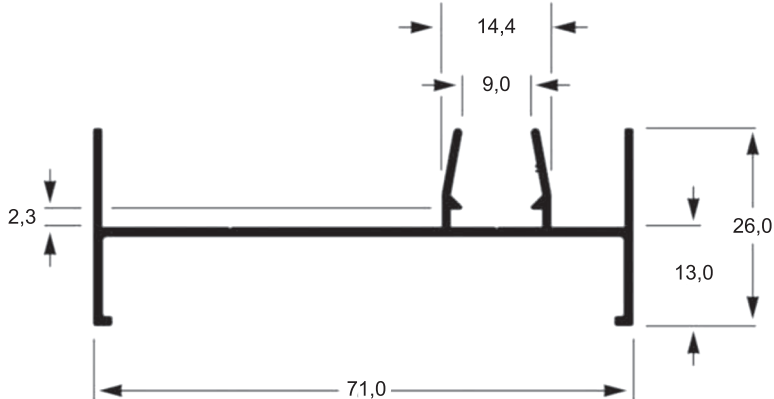

**SU-245**

3,850 kg /br

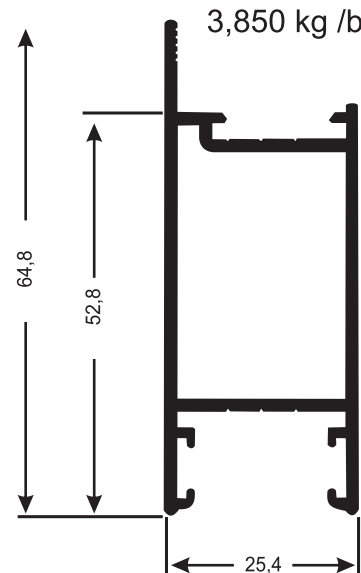



**SU-004**

3,000 kg /br  
MARCO BANDEIRA PEITORIL / CORRER 2

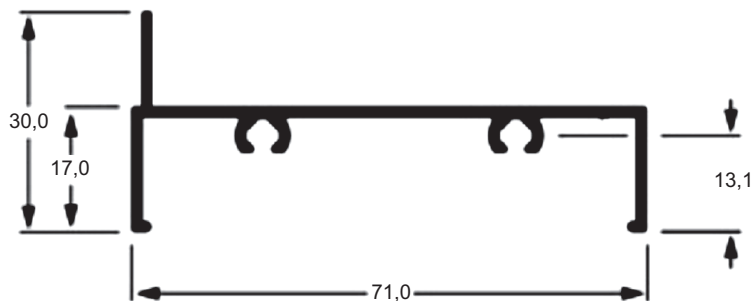

**SU-005**

6,000 kg /br  
TRAVESSA BANDEIRA CORRER 2

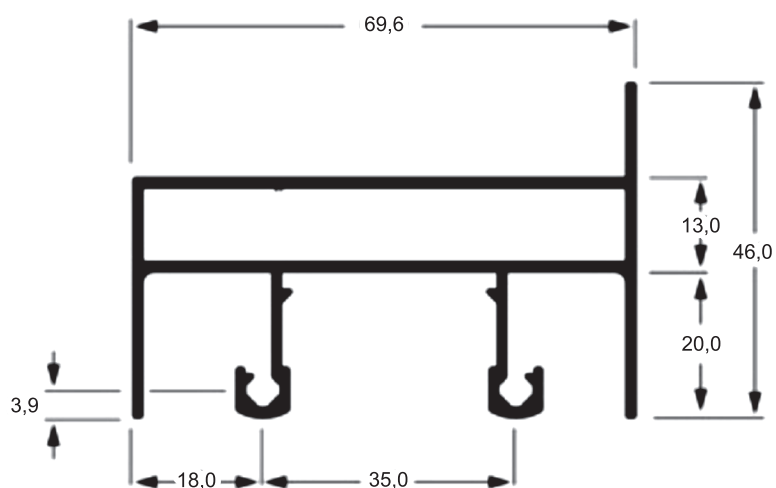

**SU-006**

6,400 kg /br

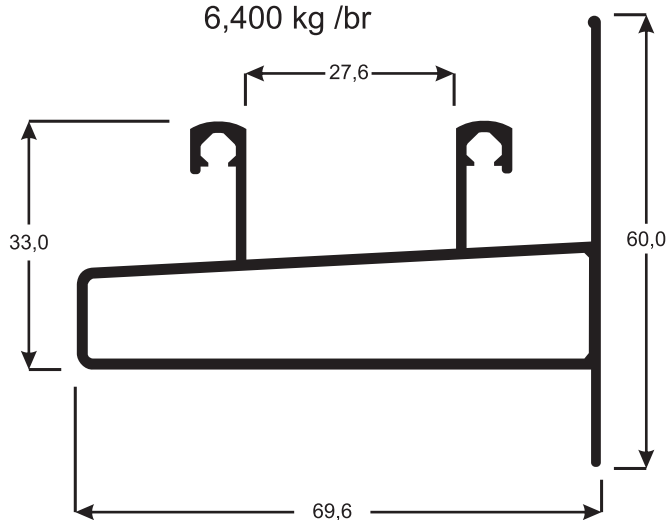

**SU-007**

2,300 kg /br  
MARCO LATERAL CORRER 2

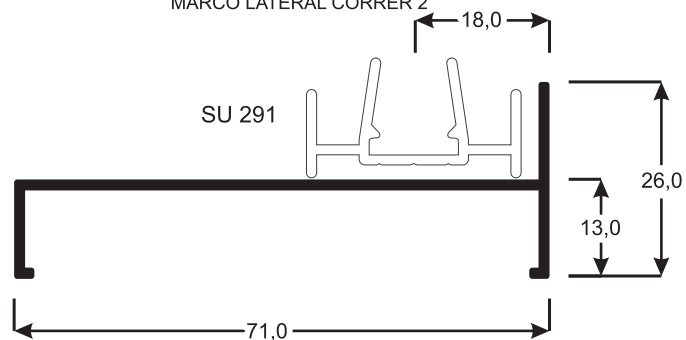



**SU 008**

1,400 kg /br  
MARCO LATERAL CORRER

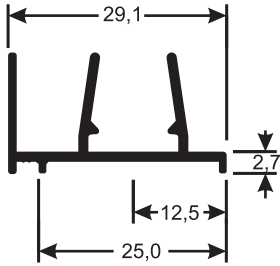

**SU-009**

4,500 kg /br

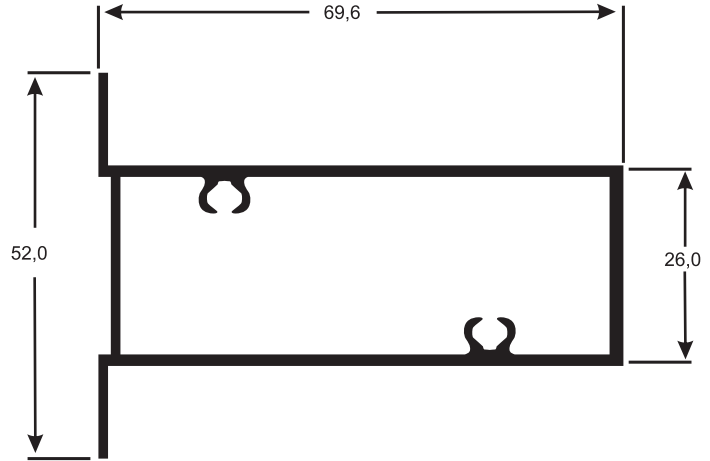

**SU-010**

6,100 kg /br  
MARCO SUPERIOR CORRER 3

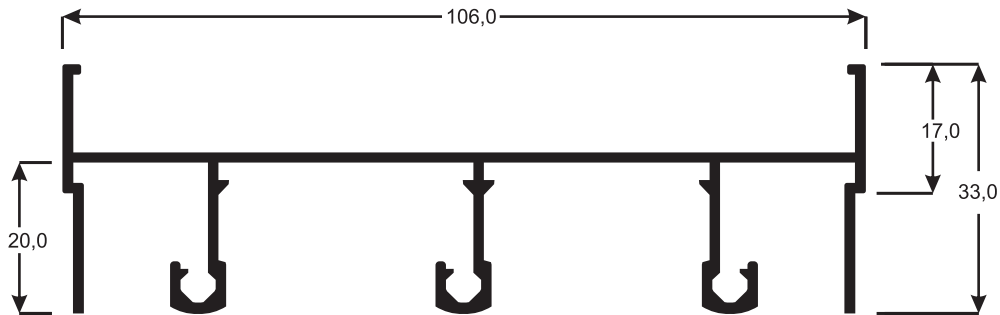

**SU-011**

5,700 kg /br  
MARCO INFERIOR CORRER 3

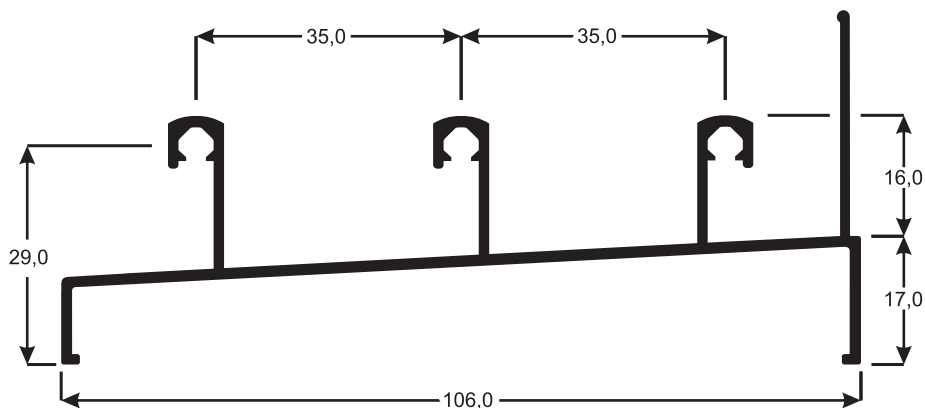



**SU-012**

3,400 kg /br  
MARCO LATERAL CORRER 3

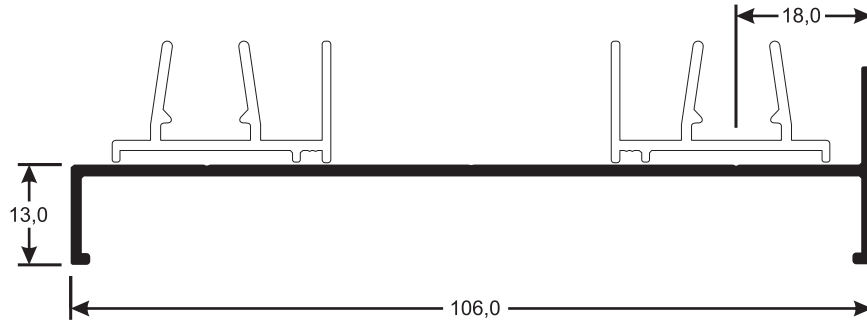

**SU-013**

4,200 kg /br  
MARCO LATERAL CORRER 3

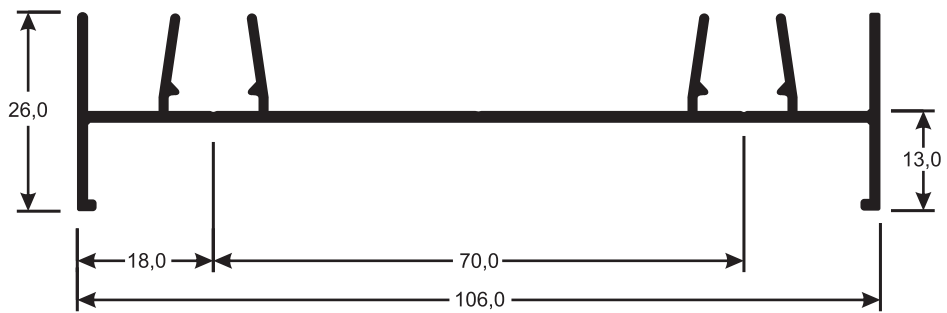

**SU-014**

3,900 kg /br  
MARCO LATERAL CORRER 3

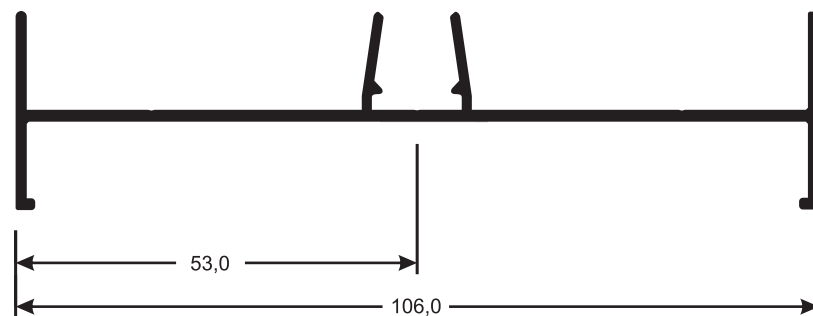

**PLS-053**

1,650 kg /br

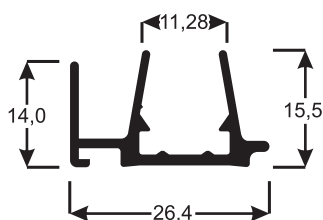

**SU 291**

1,450 kg /br  
MARCO LATERAL CORRER

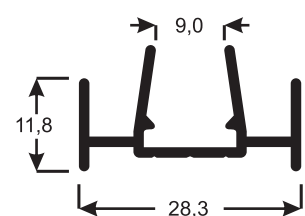



**SU-039**

3,100 kg /br  
MONTANTE DA FOLHA

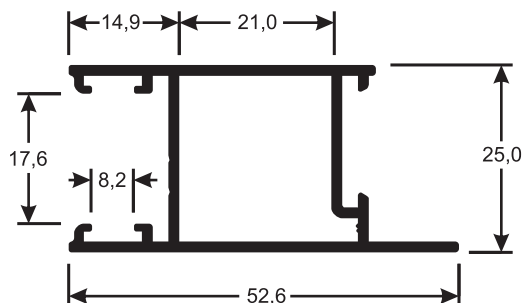

**SU-040**

2,900 kg /br  
MONTANTE MÃO DE AMIGO

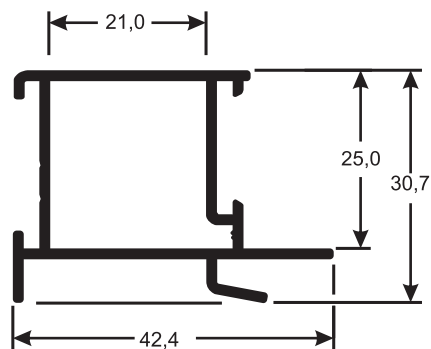

**SU-041**

3,000 kg /br  
MONTANTE MÃO DE AMIGO

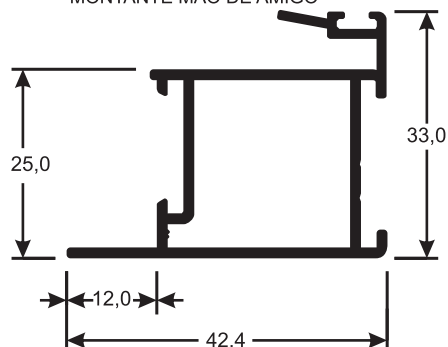

**SU-042**

3,400 kg /br  
MONTANTE MÃO DE AMIGO

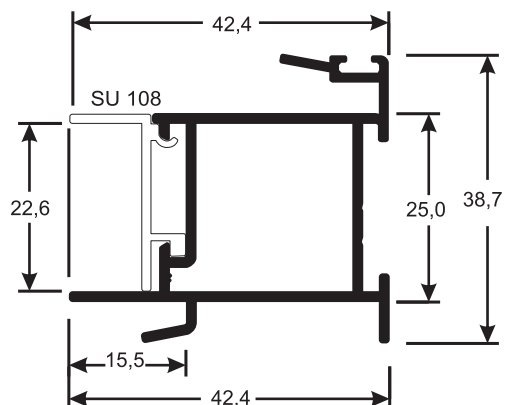

**SU-102**

0,700 kg /br

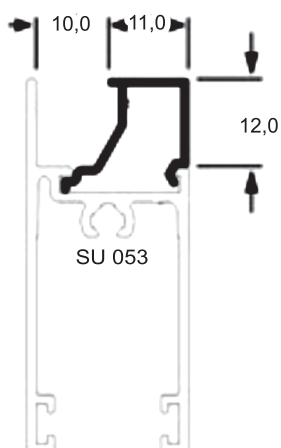

**SU-187**

2,850 kg /br  
TRAVESSA FOLHA VENEZIANA

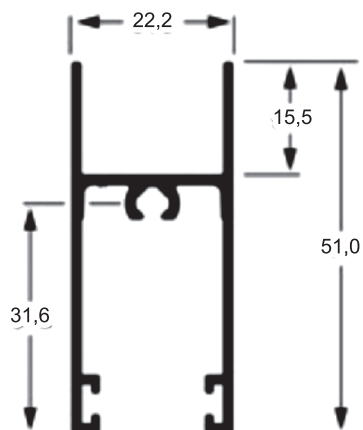



**SU-043**

5,100 kg /br

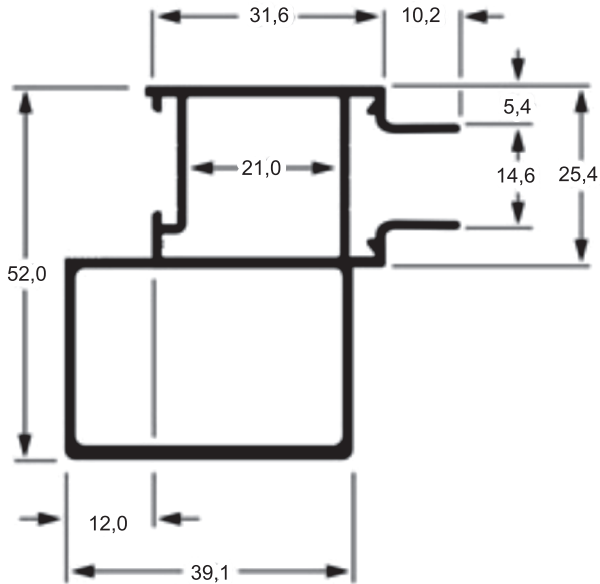

**SU-047**

5,800 kg /br

MONTANTE MÃO DE AMIGO

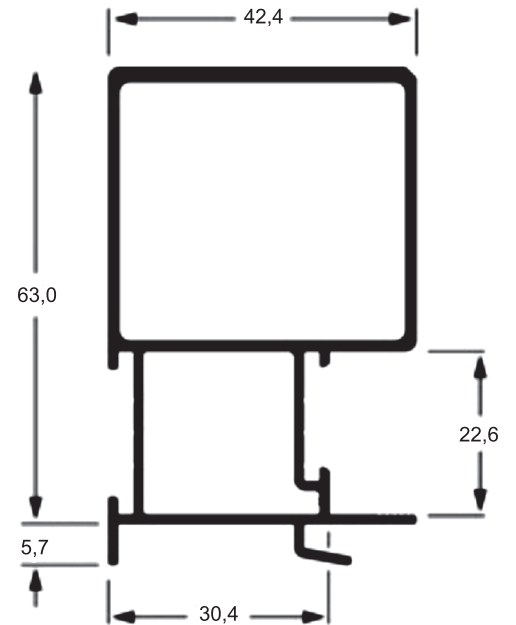

**SU-049**

5,400 kg /br

MONTANTE MÃO DE AMIGO

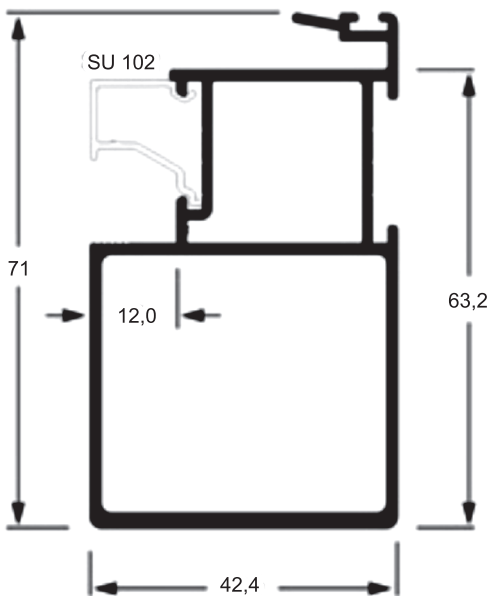

**SU-053**

3,000 kg /br

TRAVESSA FOLHA CORRER

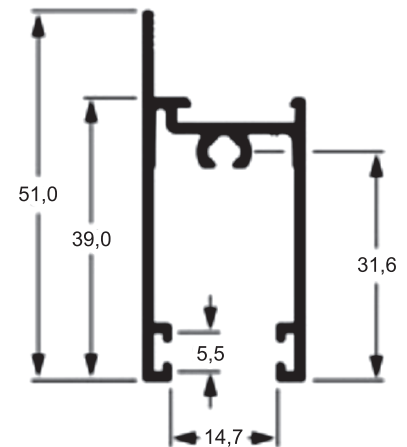



**SU-069**

3,400 kg /br  
MONTANTE MÃO DE AMIGO

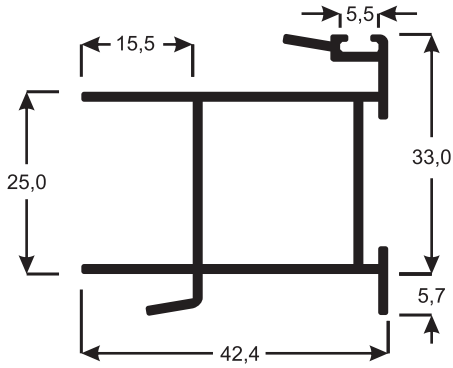

**SU-070**

3,200 kg /br  
MONTANTE MÃO DE AMIGO

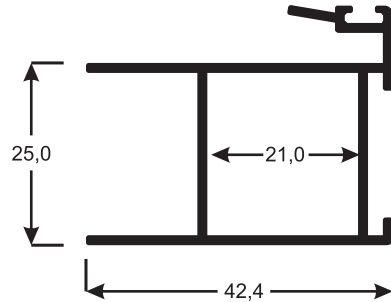

**SU-079**

2,100 kg /br  
MARCO MAXIMAR

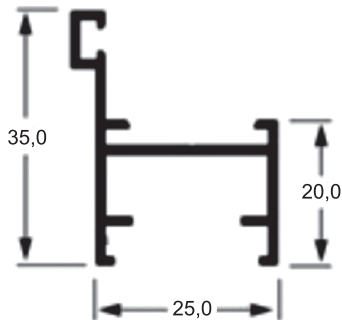

**SU-080**

2,100 kg /br  
TRAVESSA SUPERIOR FOLHA 45°

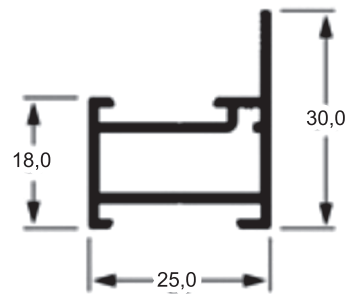

**SU-081**

2,100 kg /br  
MONTANTE FOLHA MAX

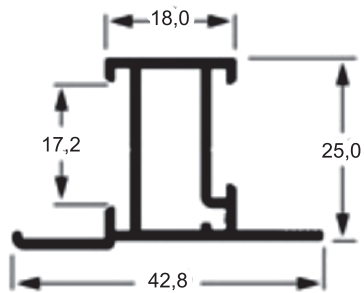

**SU-200**

2,100 kg /br

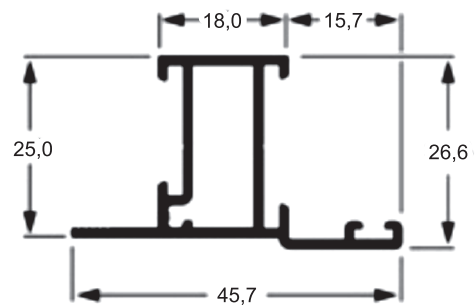



**SU-082**

2,300 kg /br  
TRAVESSA FOLHA MAX

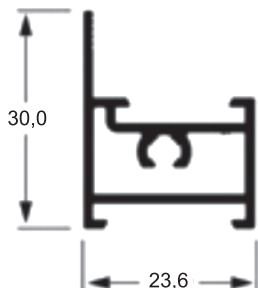

**SU-083**

0,900 kg /br  
PINGADEIRA

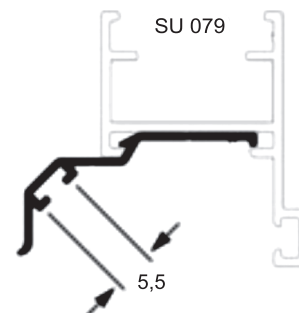

**SU-085**

3,100 kg /br  
CÓLUNA MARCO

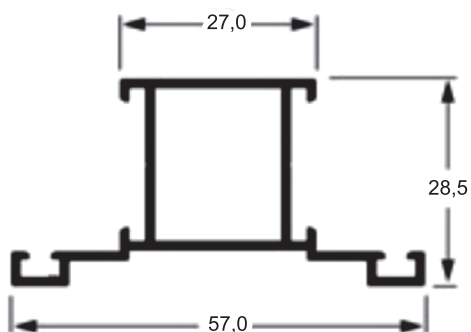

**SU-086**

3,100 kg /br  
CÓLUNA MARCO

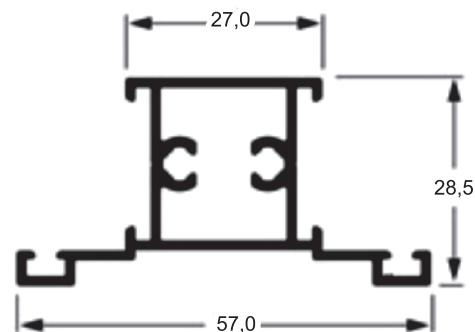

**SU-088**

1,900 kg /br  
MARCO INFERIOR

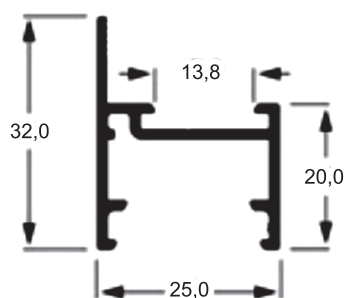

**SU-103**

0,800 kg /br  
BAGUETE MAX SUPREMA

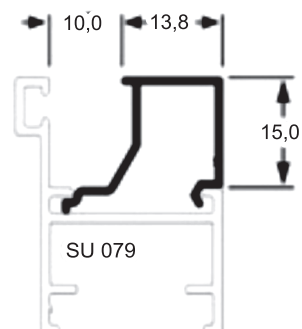



**SU-225**

6,000 kg /br

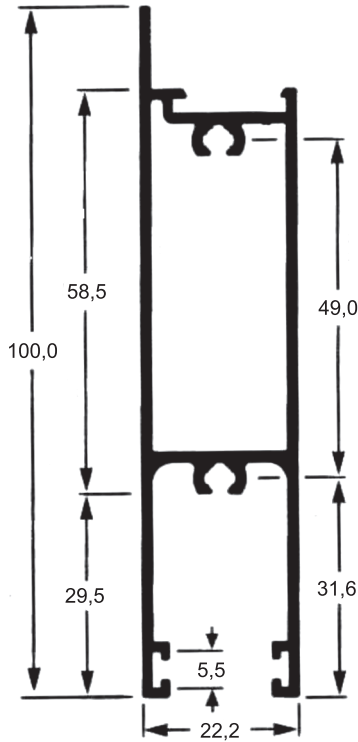

**SU-227**

3,300 kg /br

TRAVESSA CENTRAL DA FOLHA

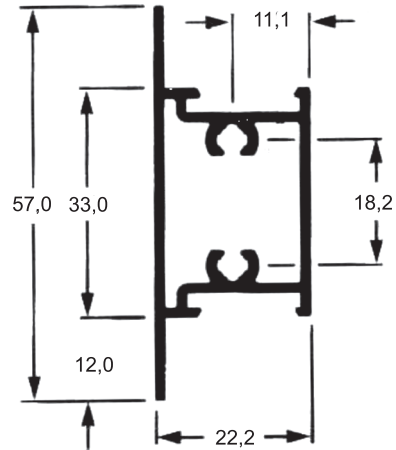

**SU-280**

4,300 kg /br

MONTANTE LATERAL DA FOLHA

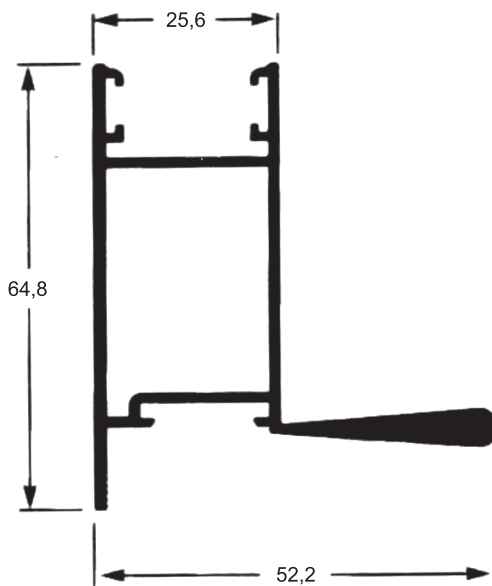

**SU-192**

3,100 kg /br

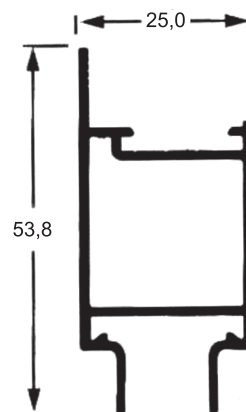



**SU-228**

3,900 kg /br  
MARCO INFERIOR CORRER 2 FOLHAS

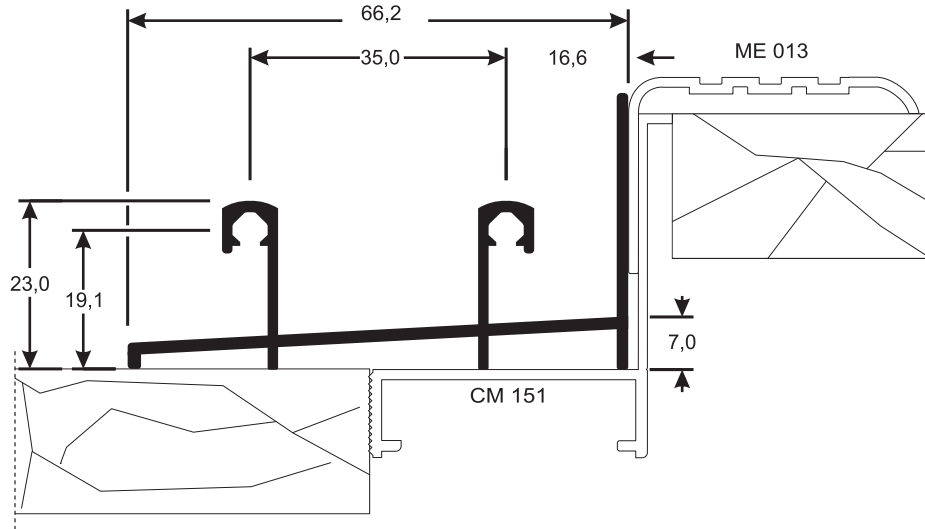

**SU-279**

3,371 kg /br

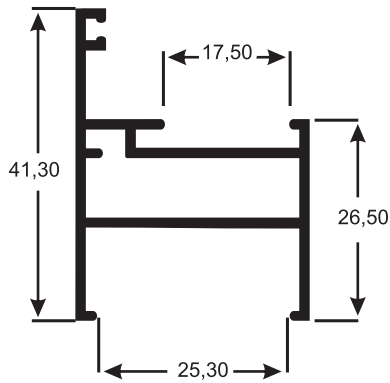

**SU-111**

3,900 kg /br

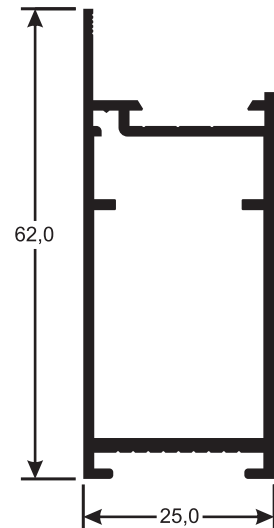

**SU-230**

5,500 kg /br  
MARCO INFERIOR CORRER FOLHAS

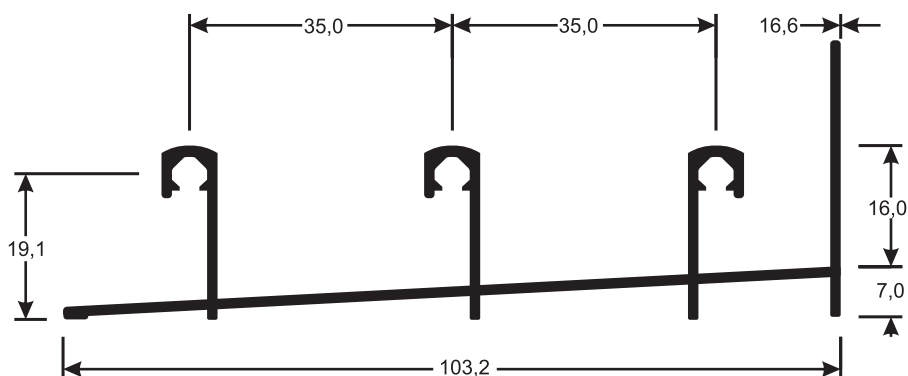



## SA-018

0,643 kg /br

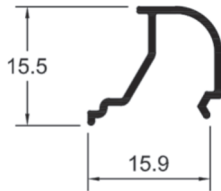

## SA-25500

3,195 kg /br

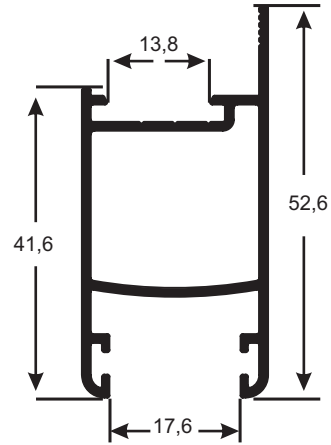

## SA-25501

2,750 kg /br

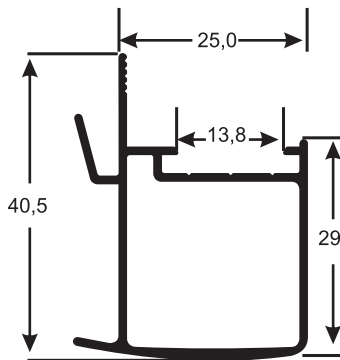

## SA-25502

2,923 kg /br

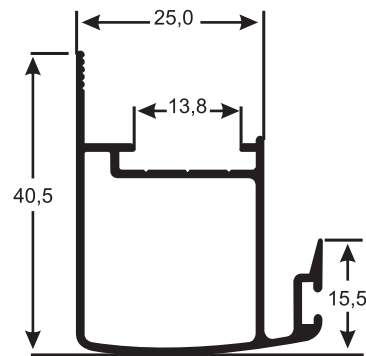

## SA-25503

3,152 kg /br

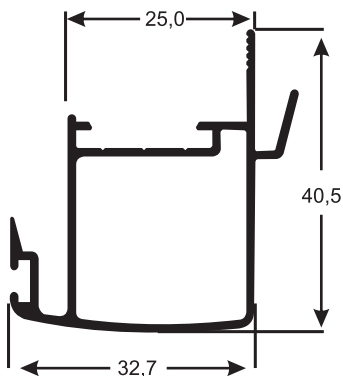

## SA-25504

3,421 kg /br\_ 4,6m

4,332 kg /br\_ 6m

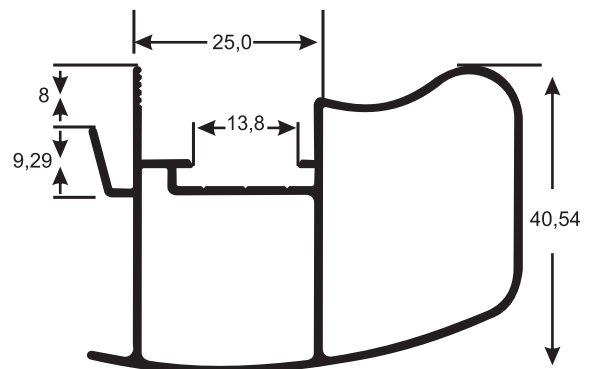



## SA-25505

3,421 kg /br\_ 4,6m  
4,332 kg /br\_6m

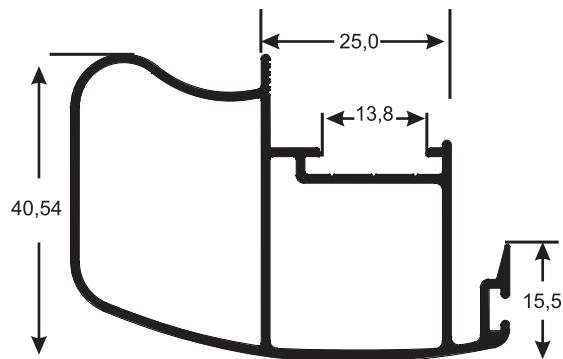

## SA-25507

2,361 kg /br

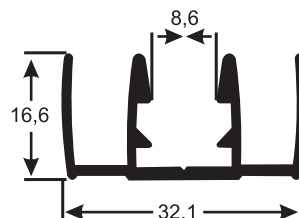

## SA-25793

5,123 kg /br

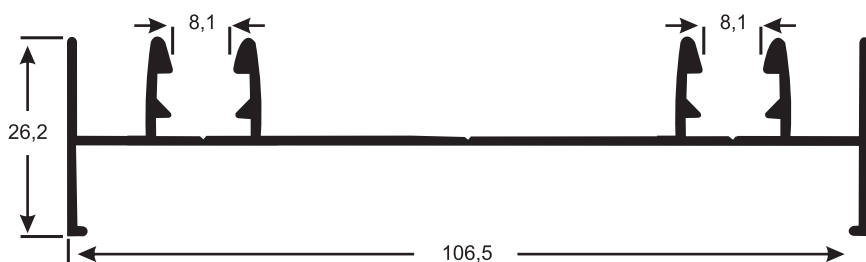

## SA-25792

4,283 kg /br

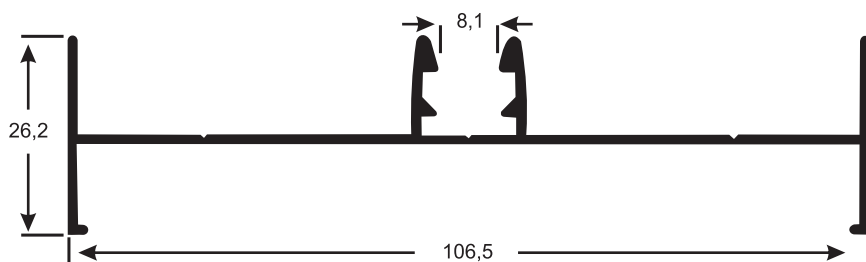

## SA-25791

3,504 kg /br

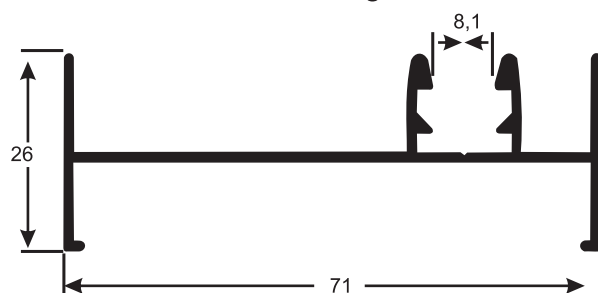

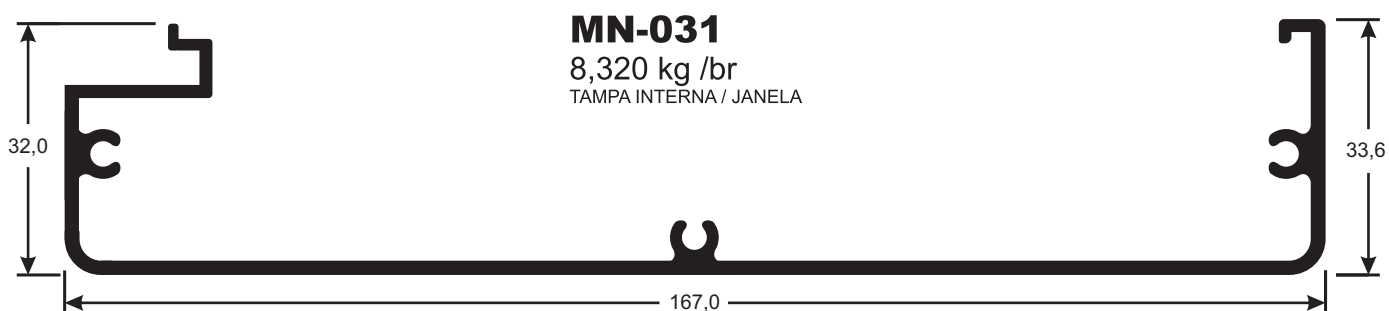
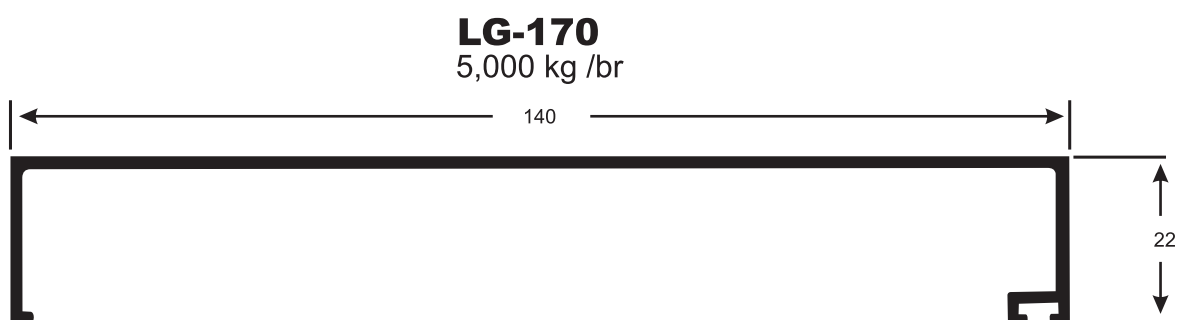
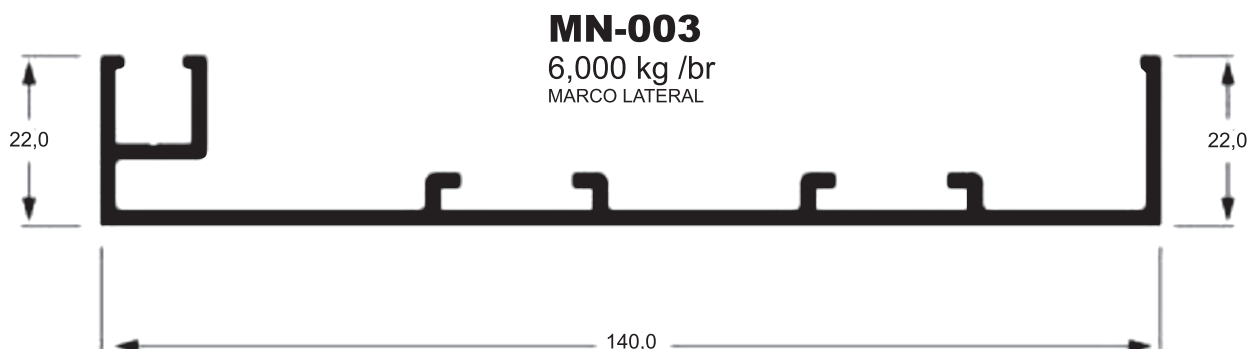
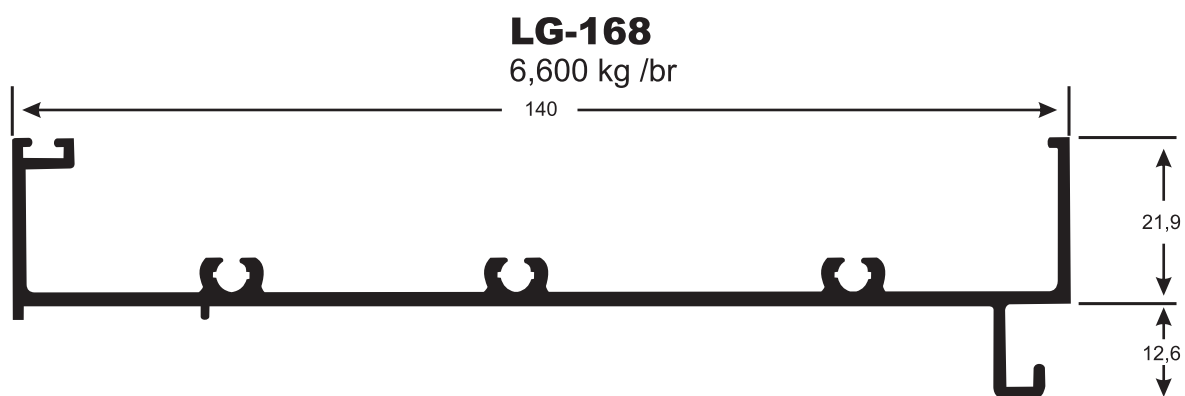
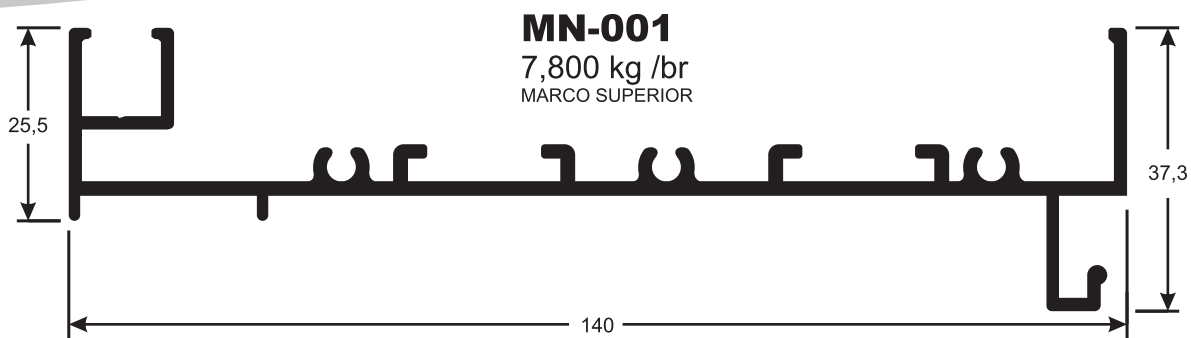



**MN-010**

8,100 kg /br  
TRILH INFERIOR

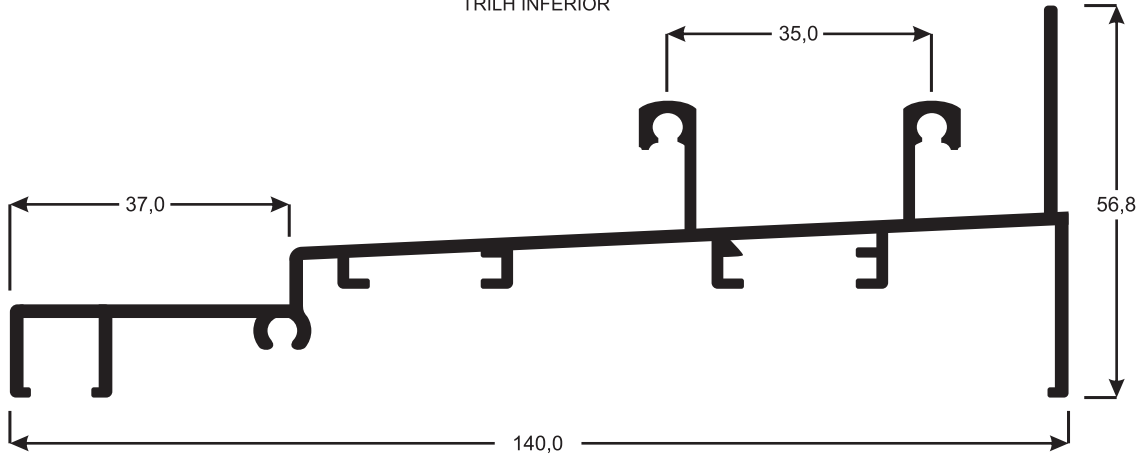

**MN-002**

4,020 kg /br

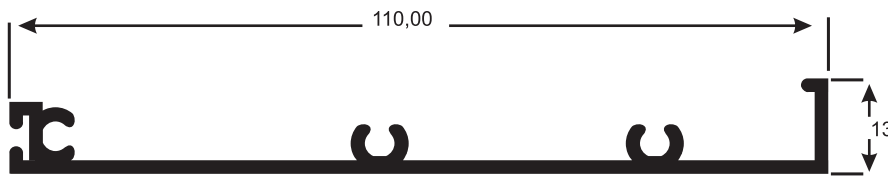

**MN-015**

5,500 kg /br  
TUBO RECOLHEDOR

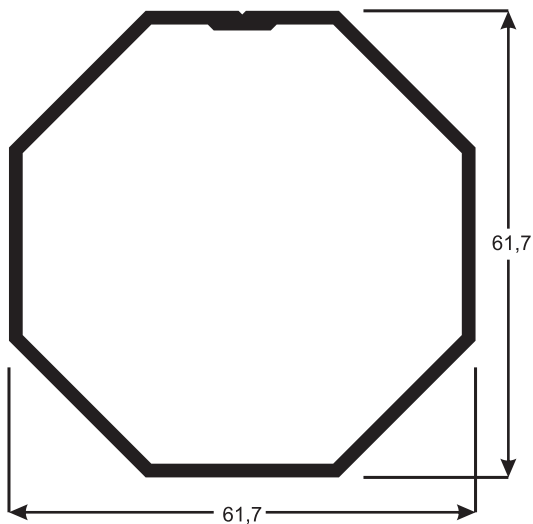

**MN-055**

2,300 kg /br

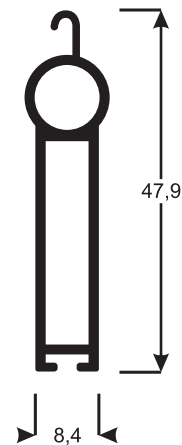





**LG-80041**

9,000 kg /br

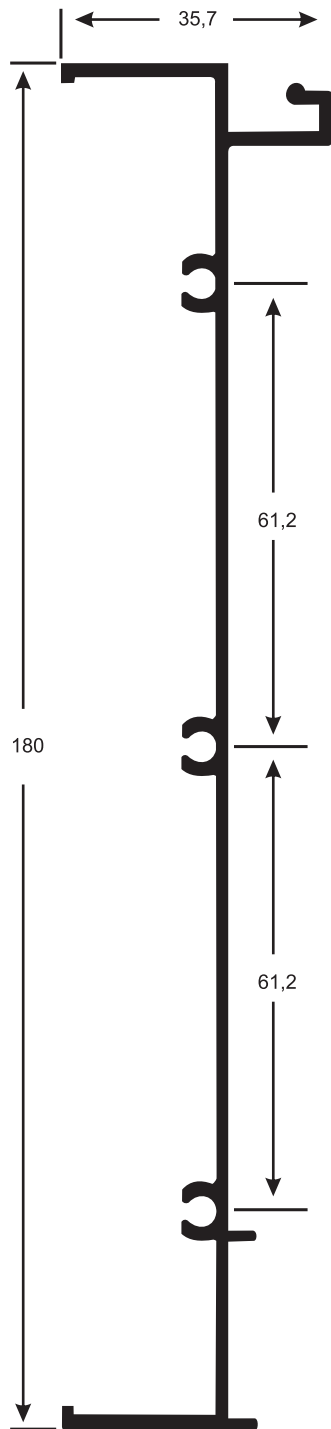

**LG-80035**

6,500 kg /br

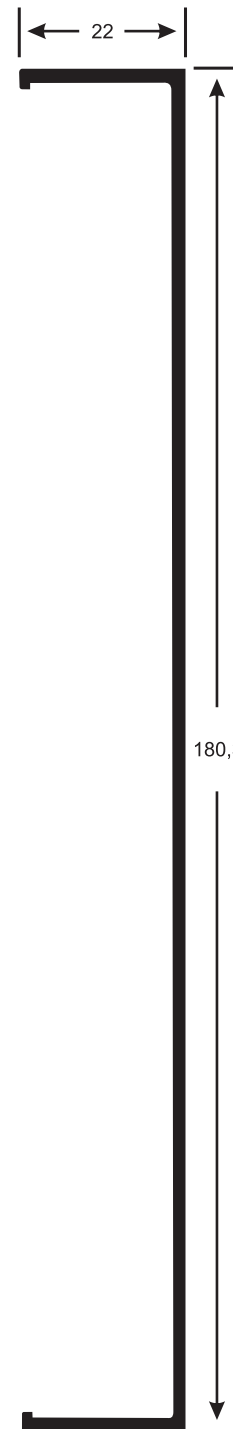



**LG-80034**  
13,500 kg /br

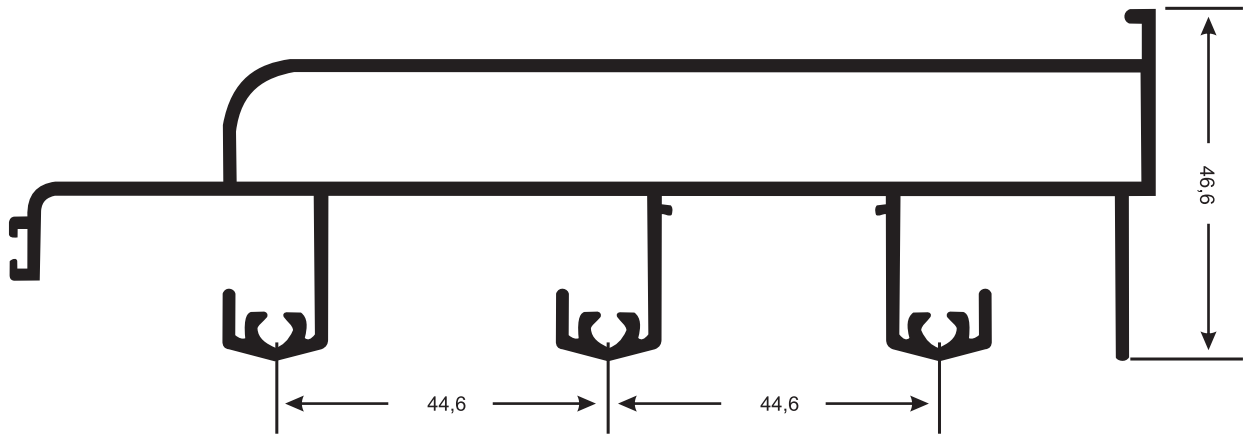

**LG-166**  
11,400 kg /br

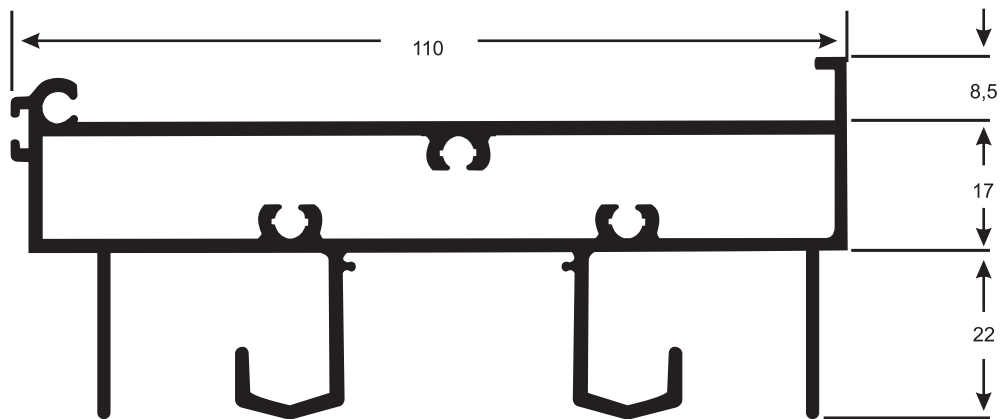



**MN-039**

8,475 kg /br  
TAMPA EXTERNA

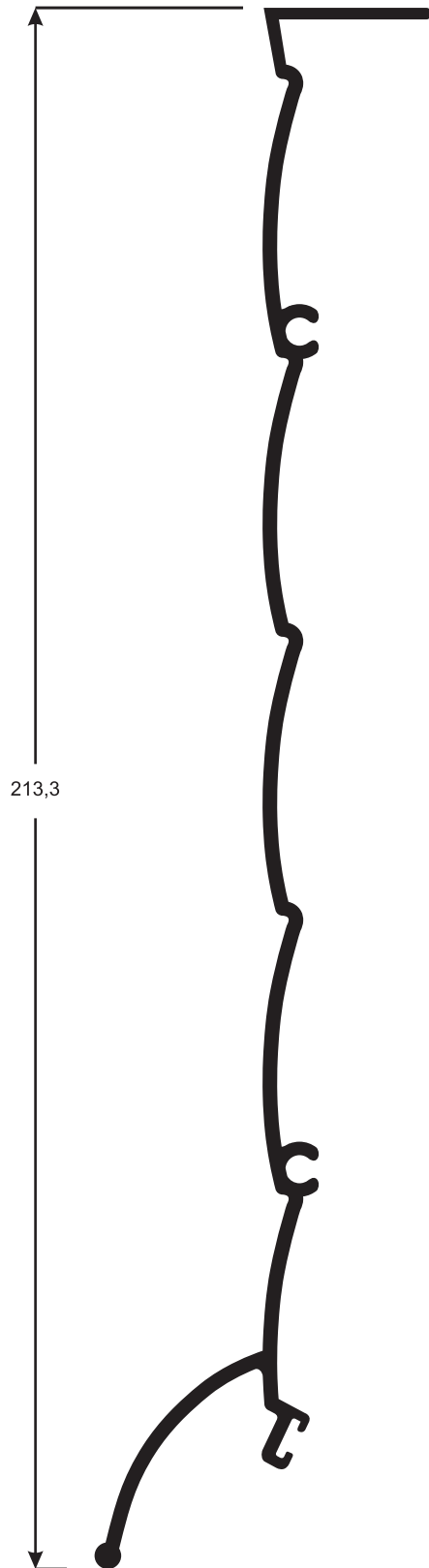

**MN-032**

11,100 kg /br  
TAMPA INTERNA

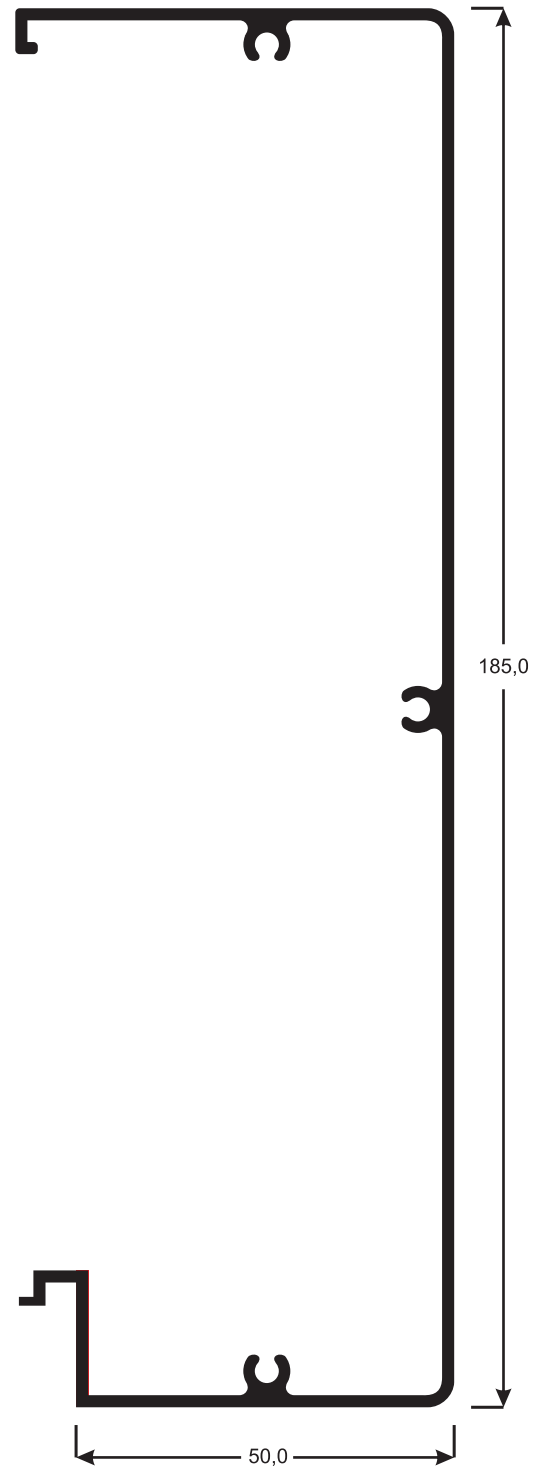



## INT-001

4,060 kg /br

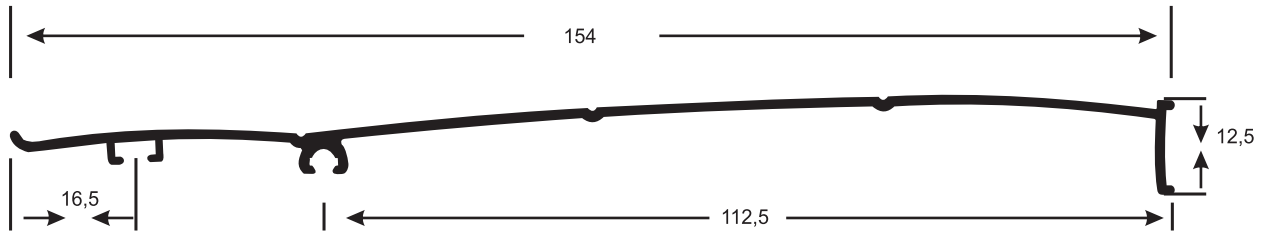

## INT-002

4,314 kg /br

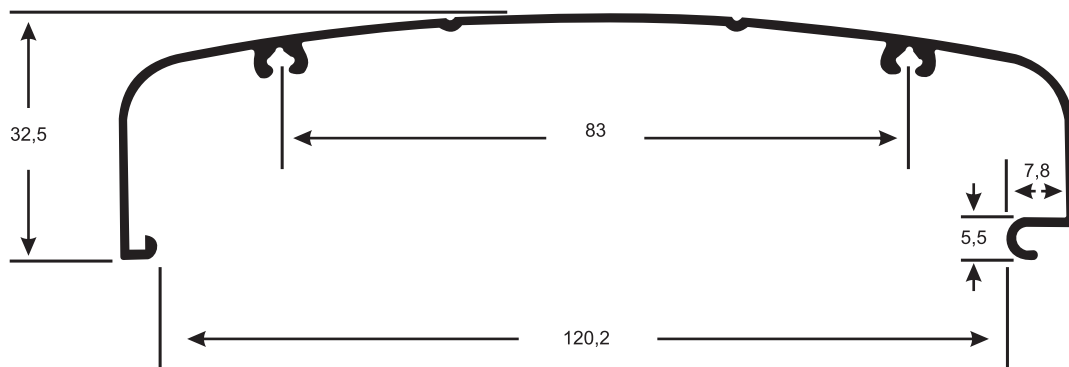

## INT-003

4,369 kg /br

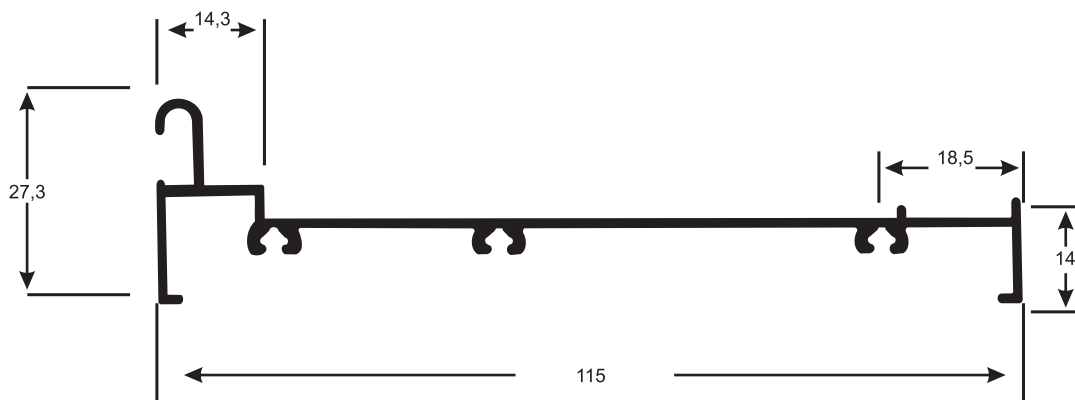



## INT-004

3,238 kg /br

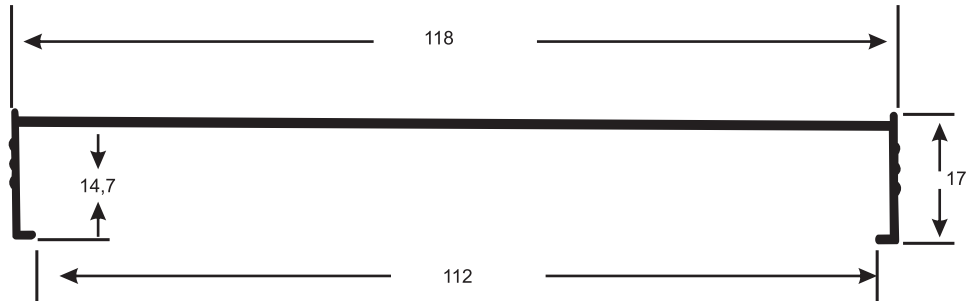

## INT-005

4,765 kg /br

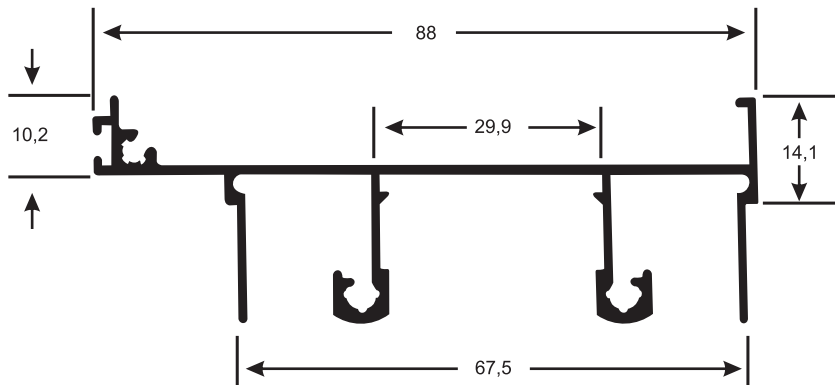

## INT-006

5,933 kg /br

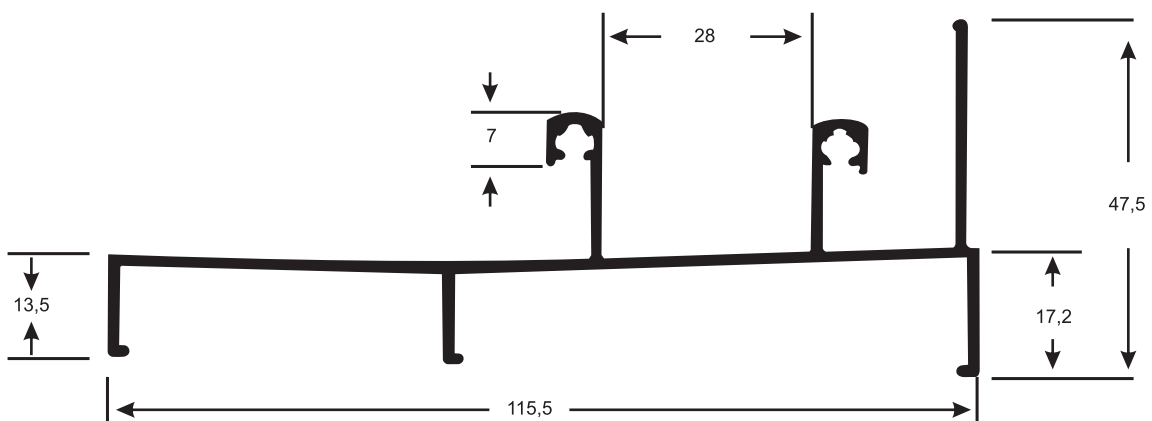



**INT-007**

5,574 kg /br

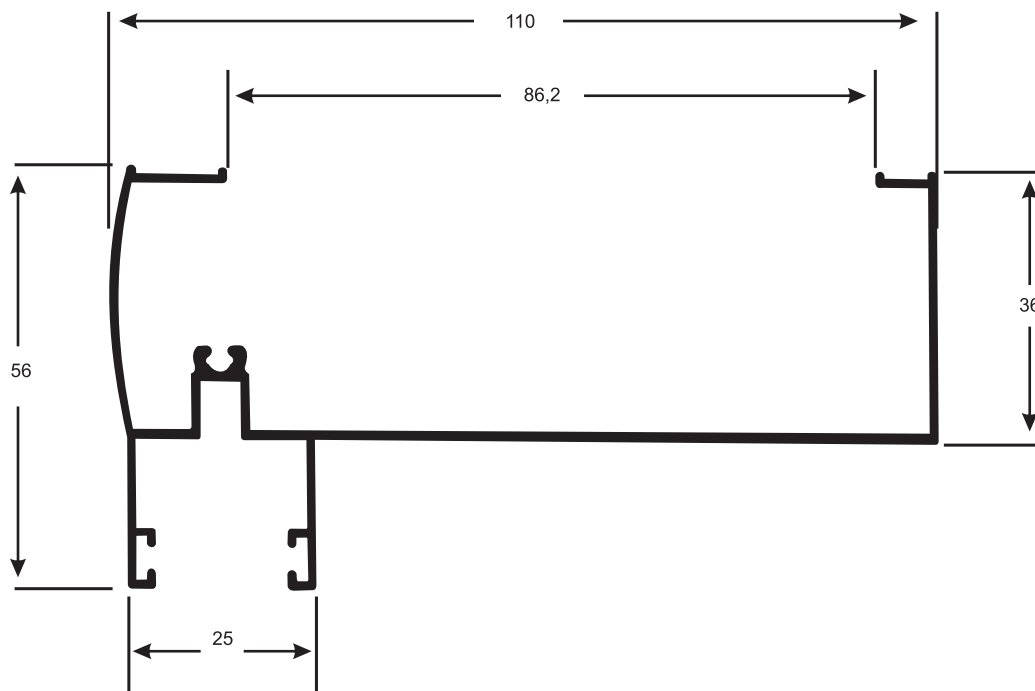

**INT-008**

3,764 kg /br

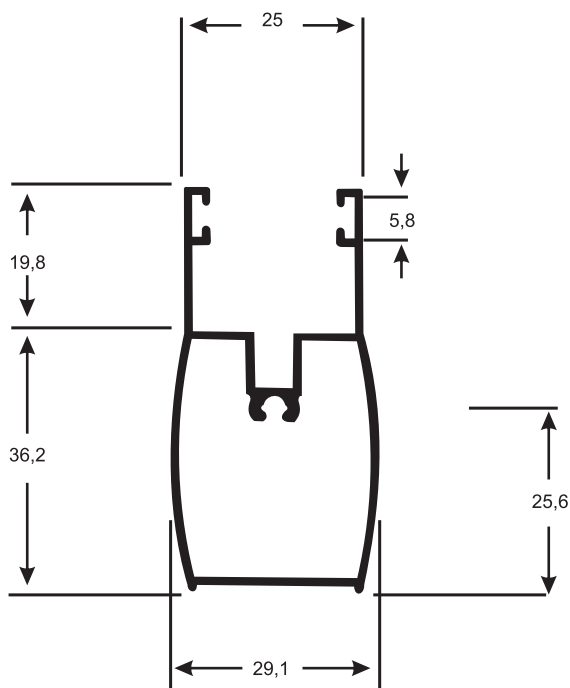



## INT-009

5,700 kg / br



## INT-010

6,970 kg / br

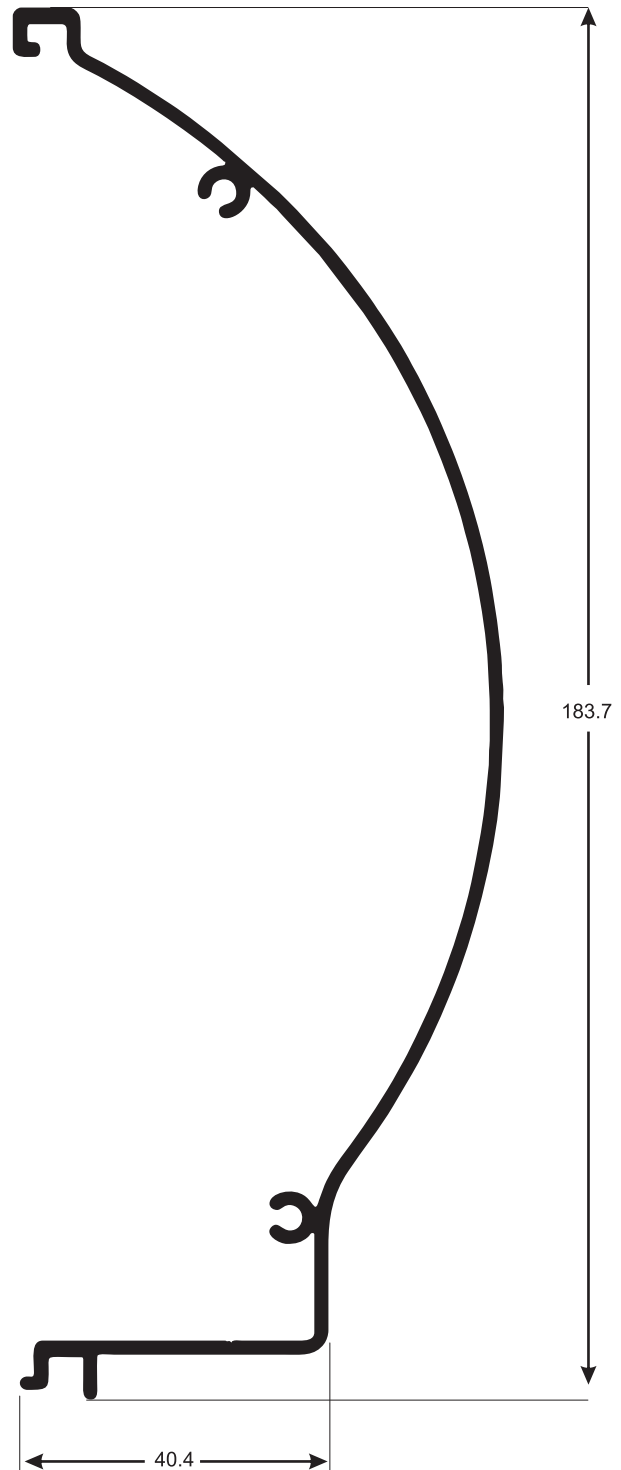



**INT-011**

5,868 kg / br

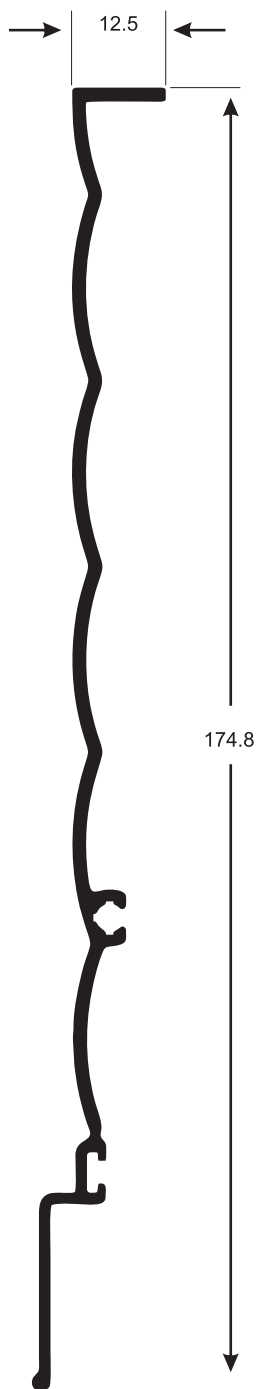



**LG - 044**

7,464 kg / br

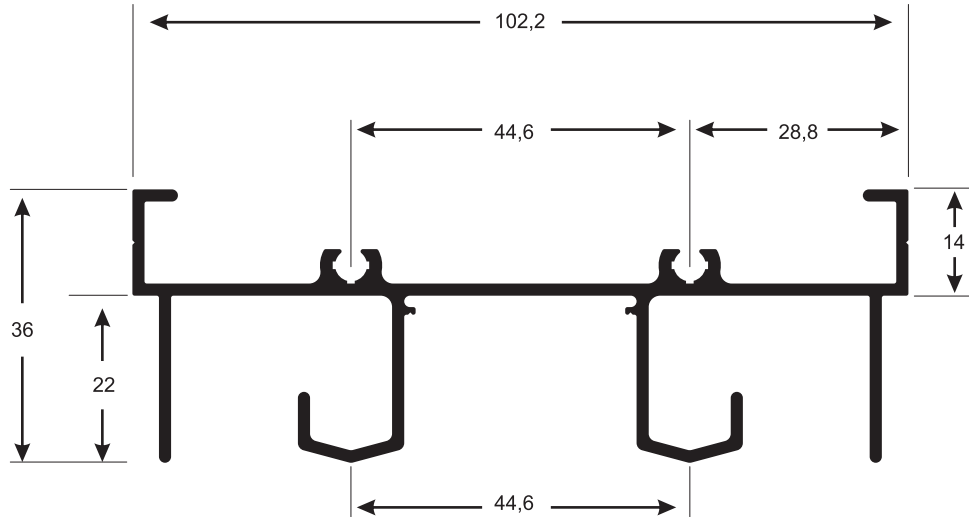

**LG - 159**

6,936 kg / br

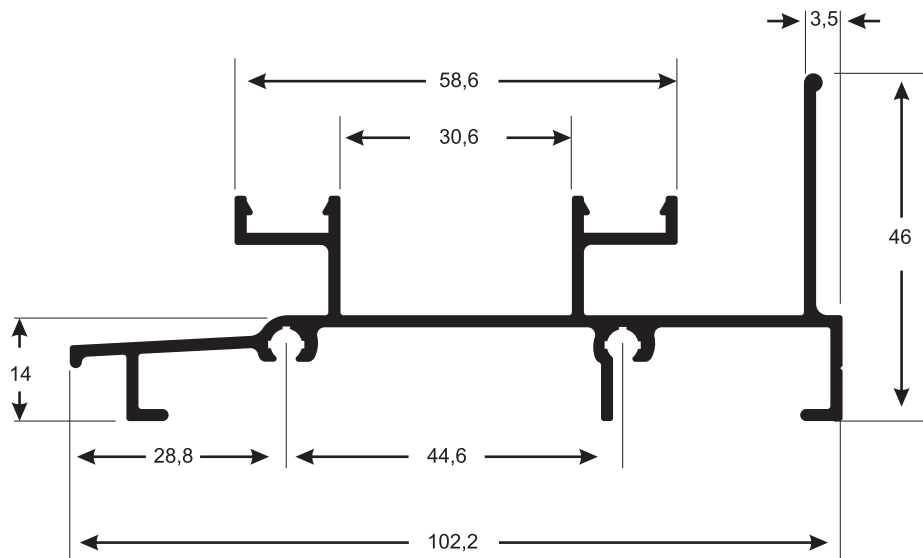

**LG - 111**

0,600 kg / br

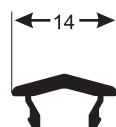



**LG - 002**  
3,834 kg / br

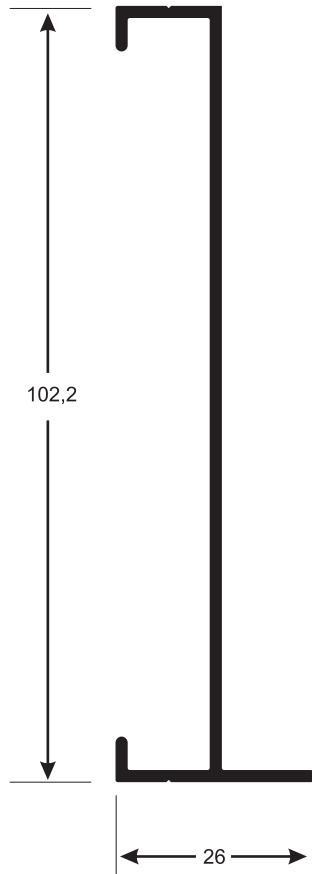

**LG - 124**  
4,638 kg / br

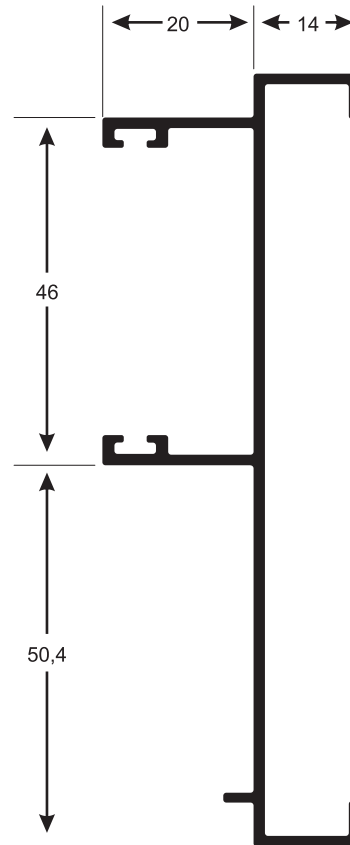

**LG - 062**  
10,596 kg / br

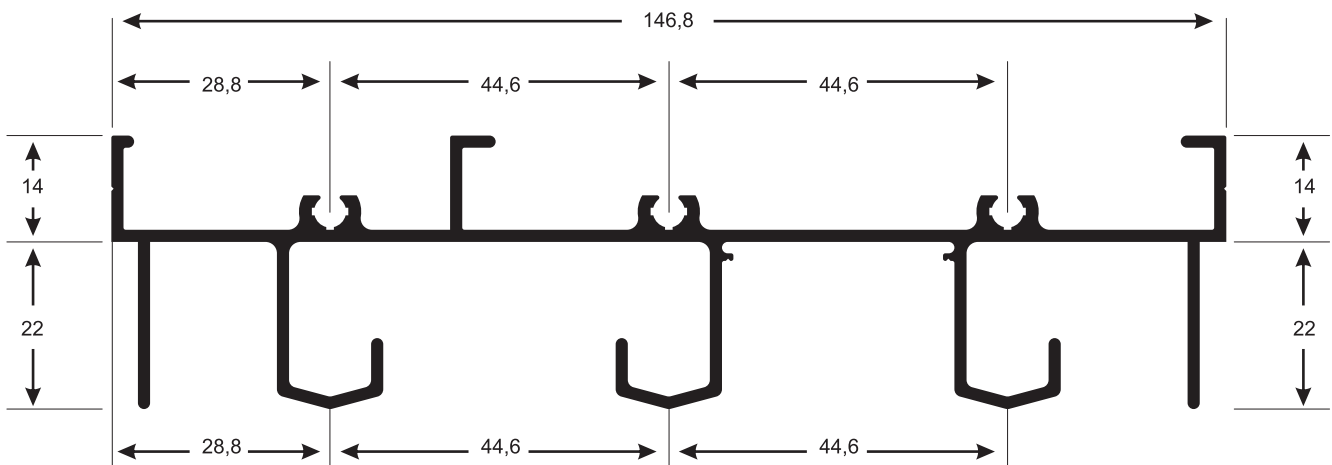



**LG - 144**

6,432 kg / br

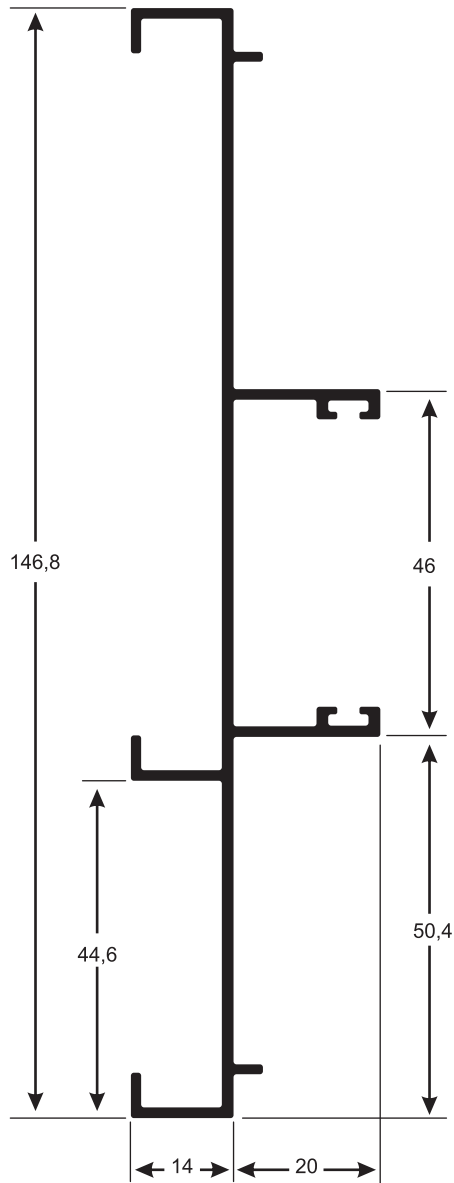

**LG - 145**

7,542 kg / br

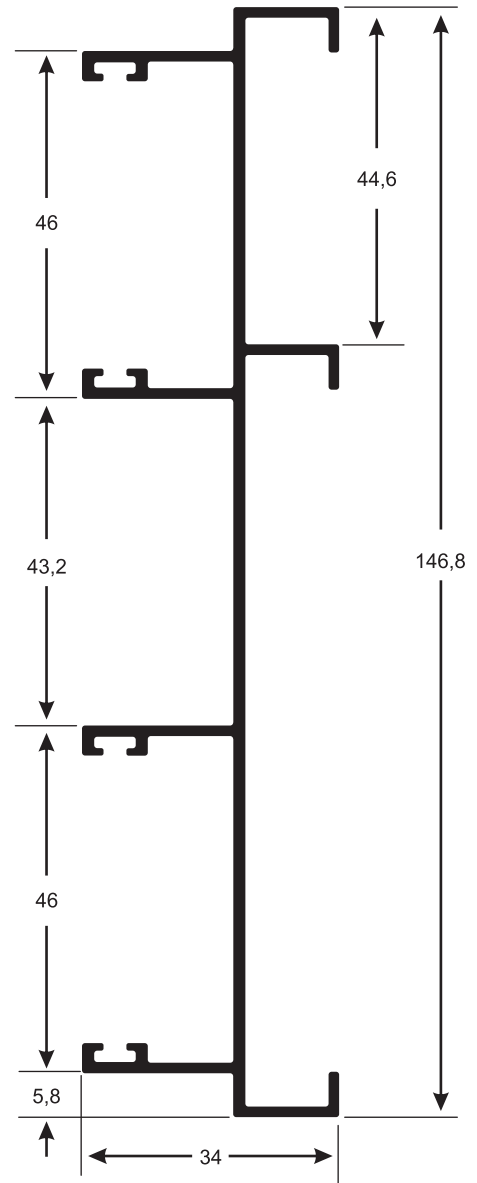

**LG - 116**

9,306 kg / br

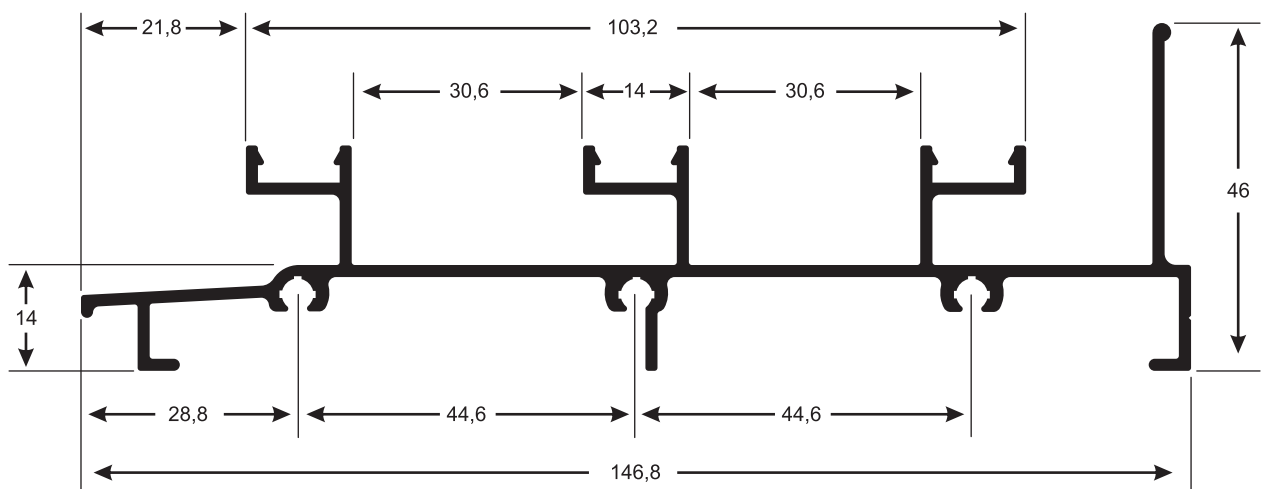



**LG - 158**  
5,256 kg / br

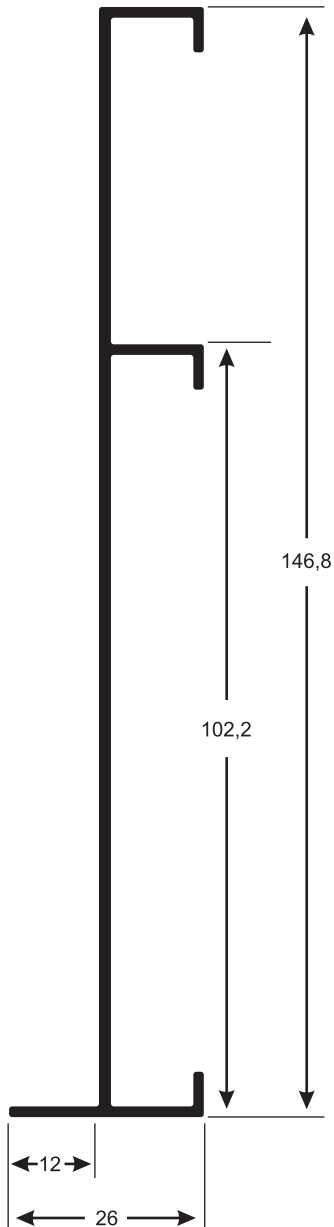

**LG - 072**  
7,500 kg / br

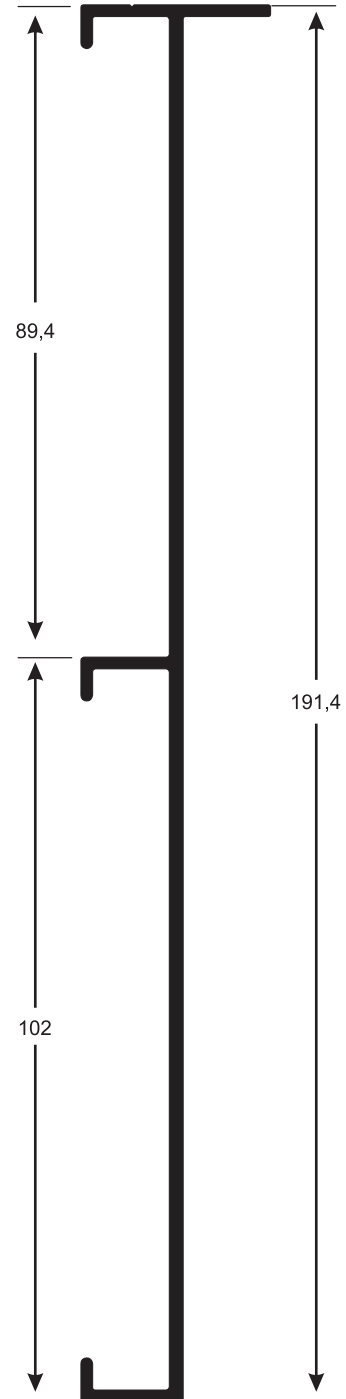

**LG - 028**  
2,724 kg / br

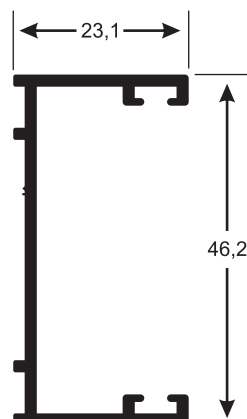



**LG - 070**  
13,638 kg / br

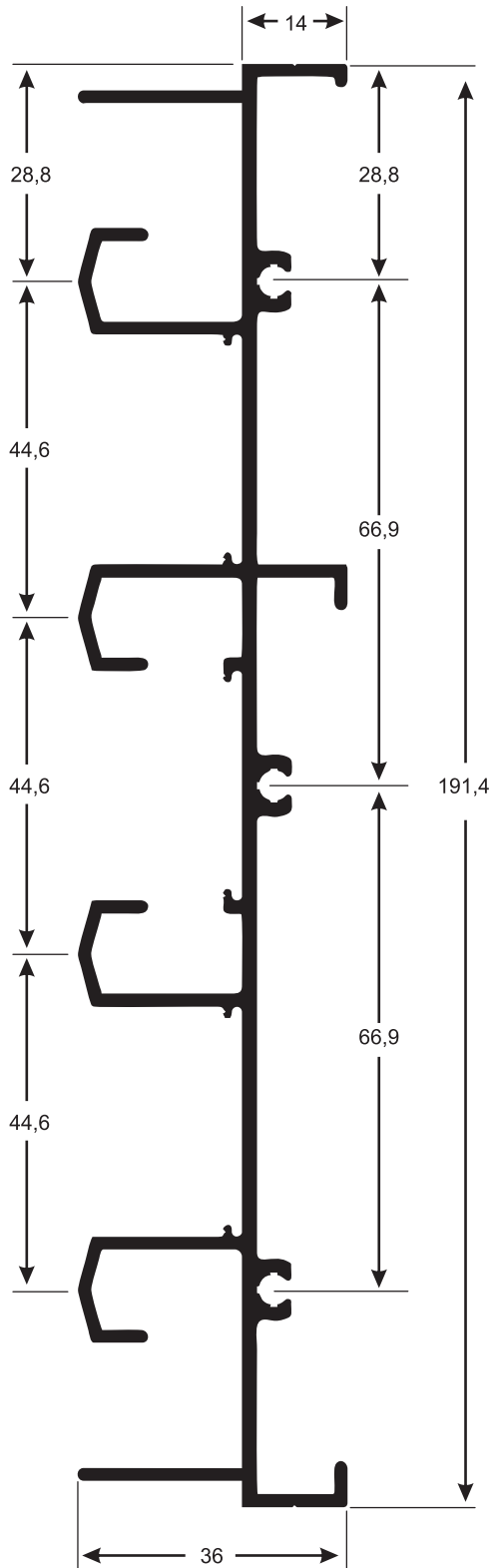

**LG - 160**  
12,492 kg / br

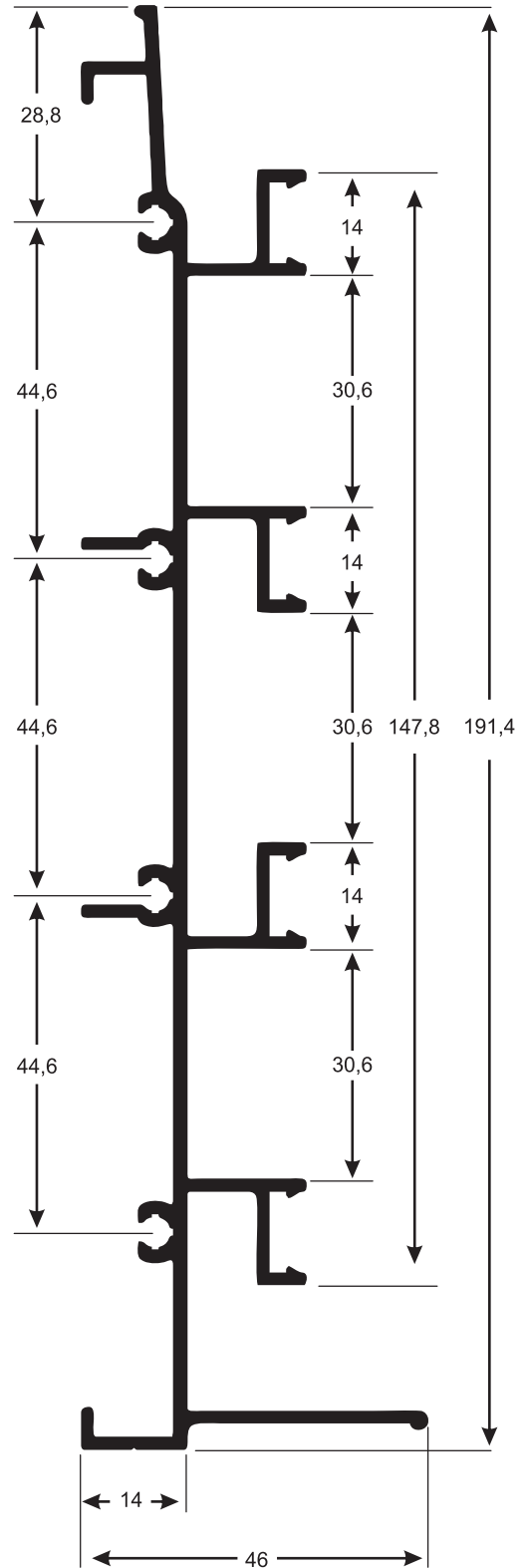



**LG - 050**

4,866 kg / br

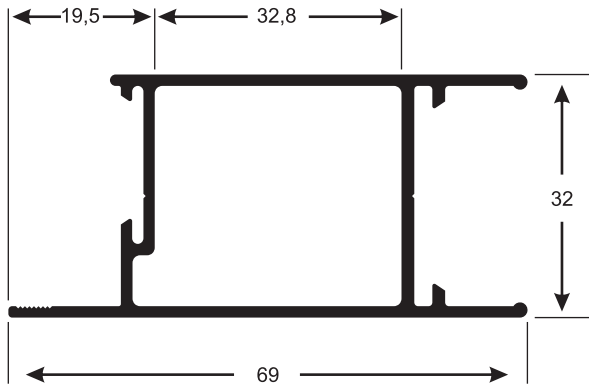

**LG - 048**

5,802 kg / br

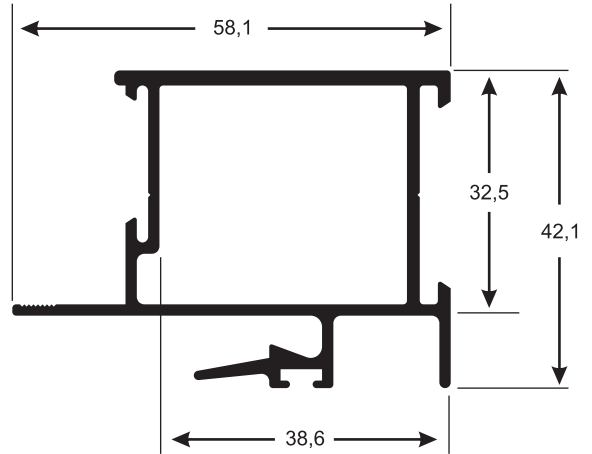

**LG - 051**

5,514 kg / br

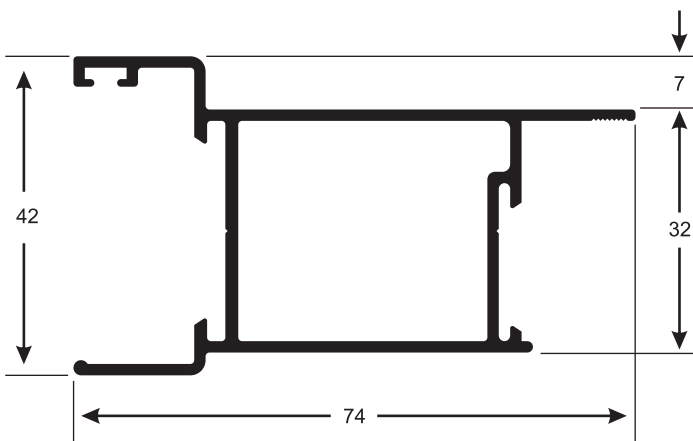

**LG - 049**

5,448 kg / br

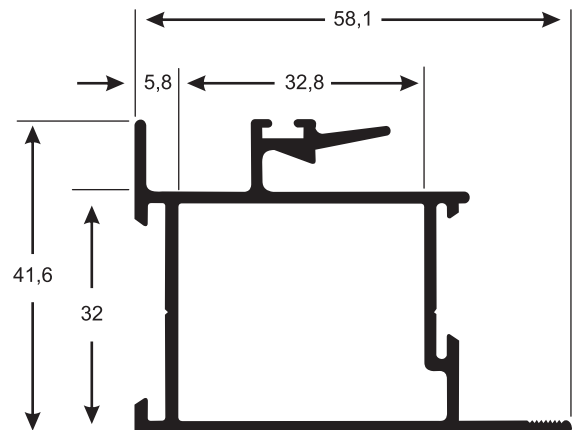

**LG - 162**

6,444 kg / br

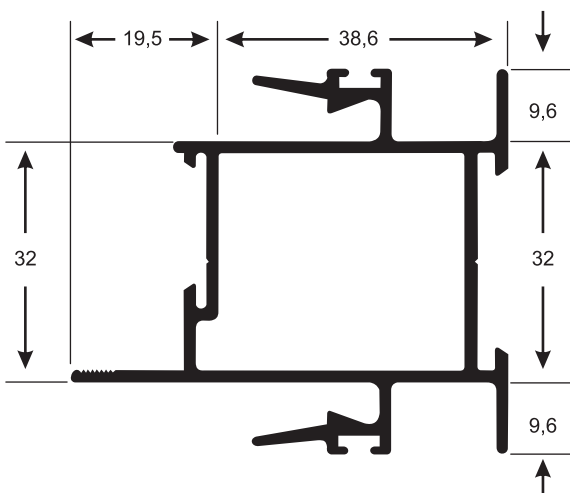

**LG - 006**

4,062 kg / br

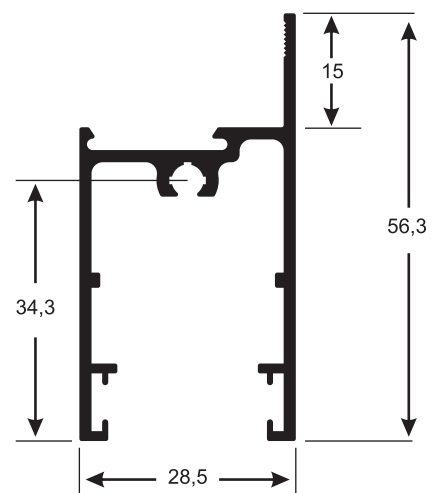



**LG-068**

2,400 kg /br

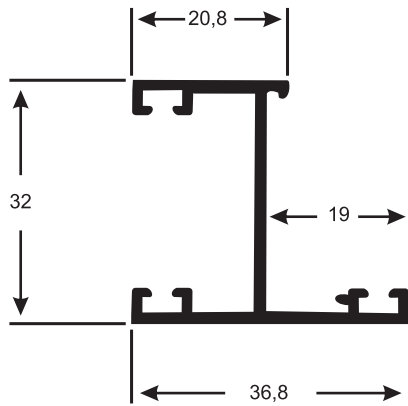

**LG-074**

4,600 kg /br

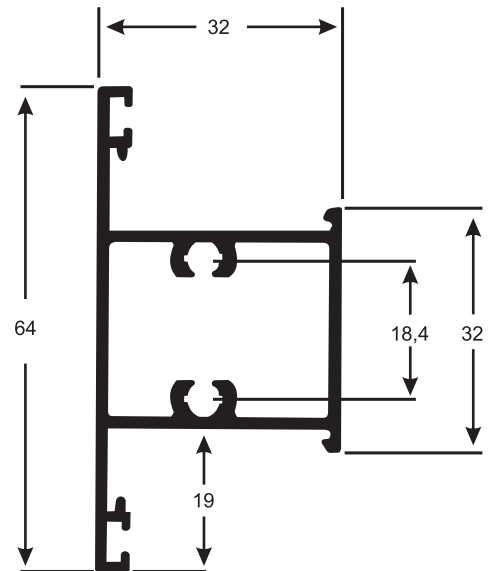

**LG-076**

4,600 kg /br

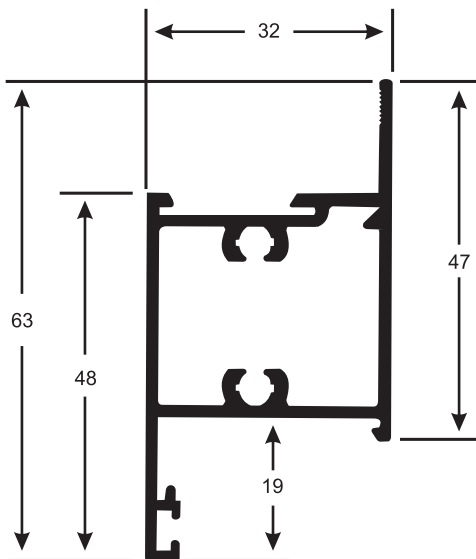

**LG-077**

2,000 kg /br

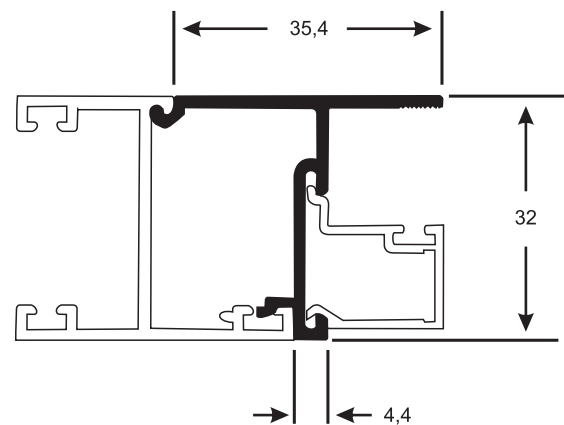



**LG-085**

3,200 kg /br

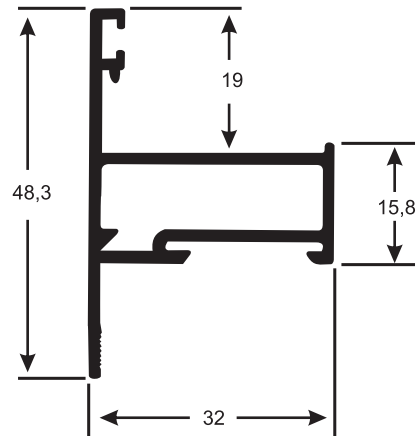

**LG-091**

0,900 kg /br

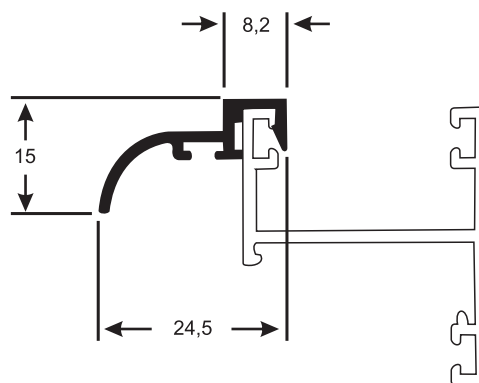



**LG - 055**  
4,548 kg / br

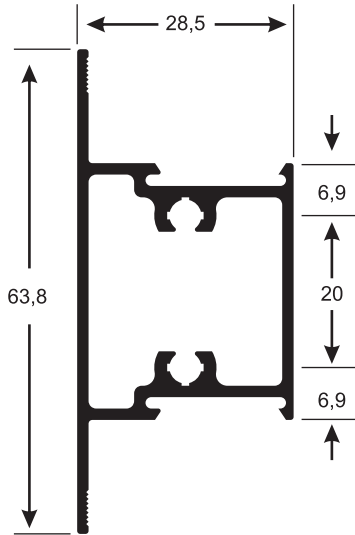

**LG - 007**  
7,374 kg / br

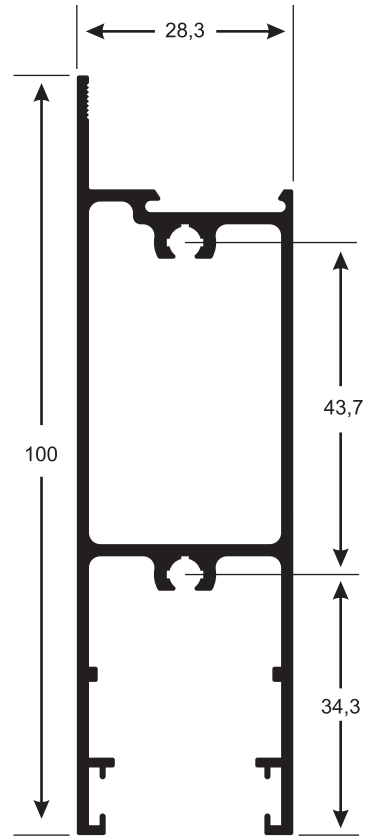

**FC - 368**  
0,780 kg / br

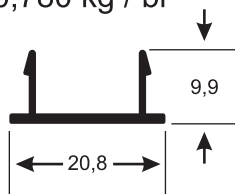

**LG - 235**  
7,374 kg / br

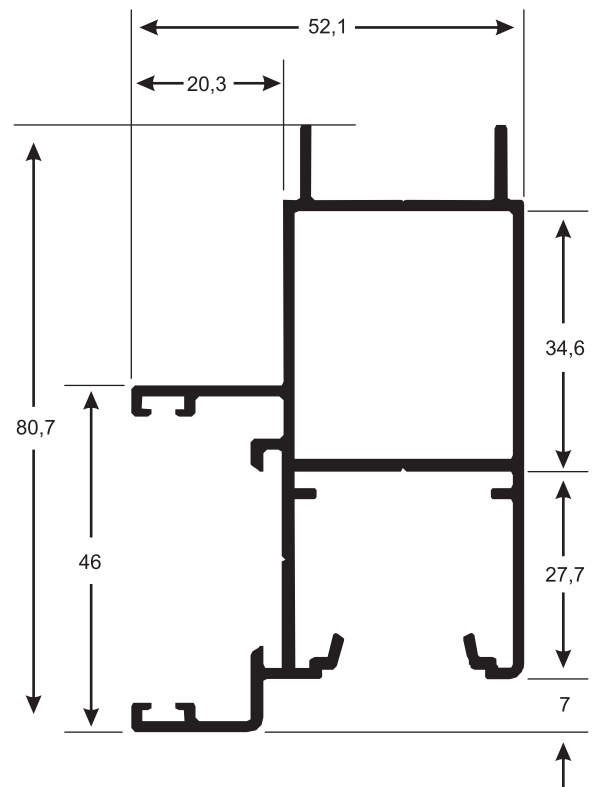



**LG - 083**

2,454 kg / br

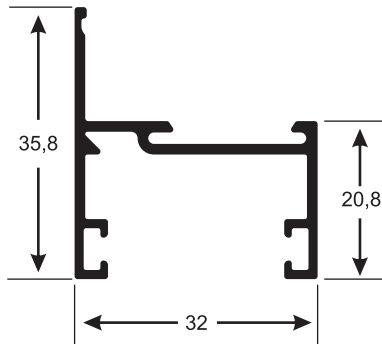

**LG - 079**

4,620 kg / br

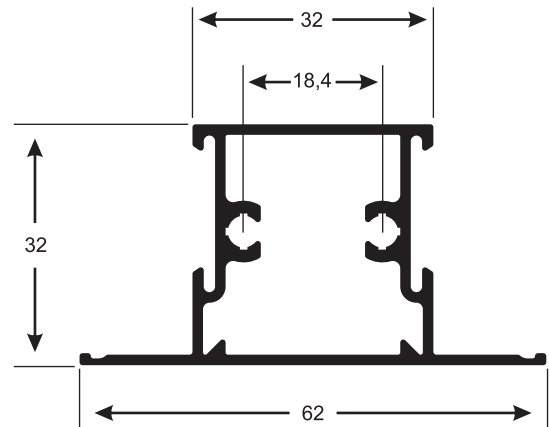

**LG - 056**

3,858 kg / br

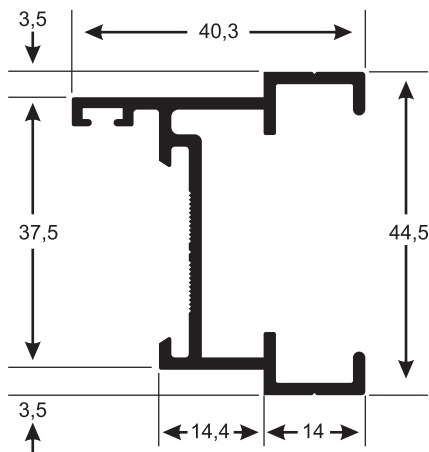

**LG - 043**

5,580 kg / br

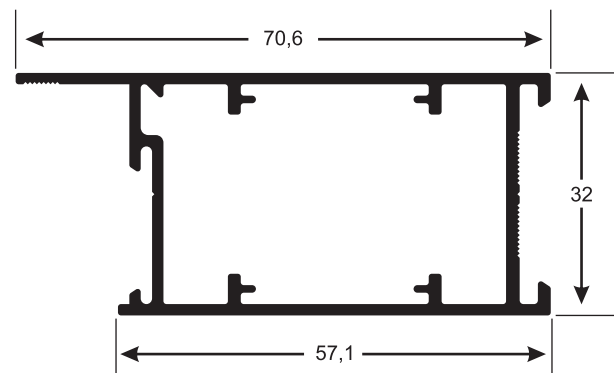

**LG - 042**

7,014 kg / br

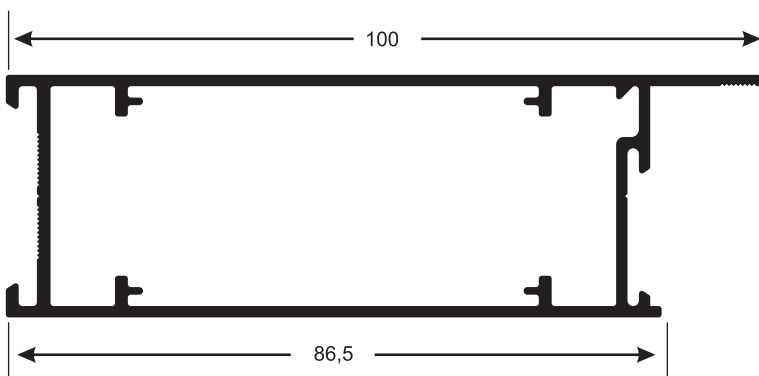

**LG - 016**

2,028 kg / br

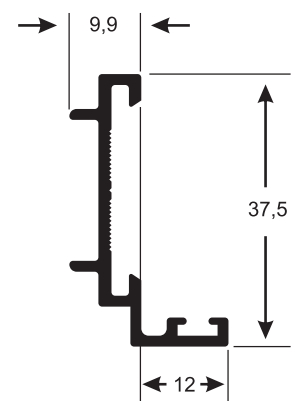



**LG - 026**  
0,948 kg / br

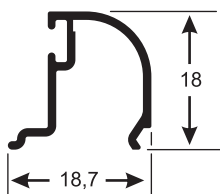

**BG - 057**  
1,020 kg / br

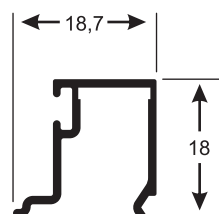

**LG - 027**  
0,894 kg / br

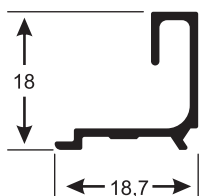

**LG - 164**  
0,960 kg / br

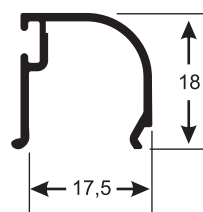

**LG - 059**  
1,014 kg / br

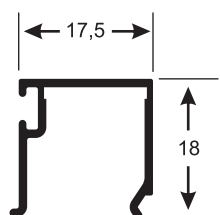

**LG - 015**  
0,882 kg / br

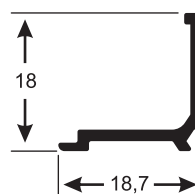



## **BX-084**

2,700 kg /br

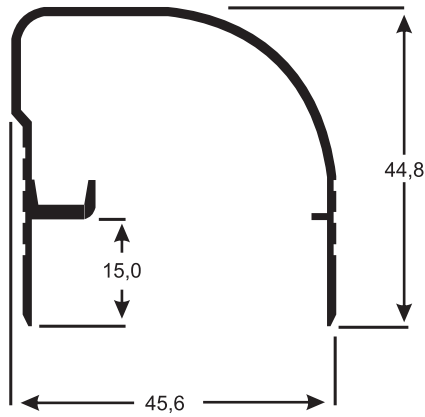

## **BX-085**

1,100 kg /br

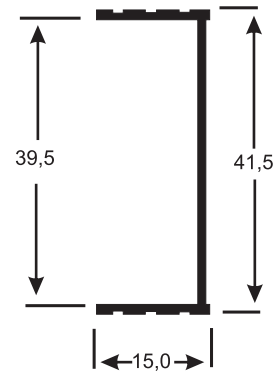

## **BX-087**

0,900 kg /br

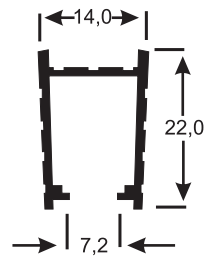

## **BX-090**

1,300 kg /br

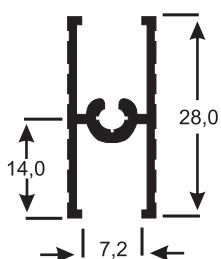

## **BX-121**

0,900 kg /br

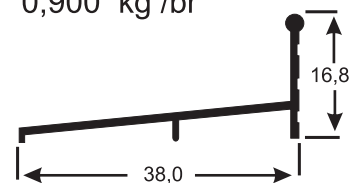



## ES - 029

1,000 kg / br

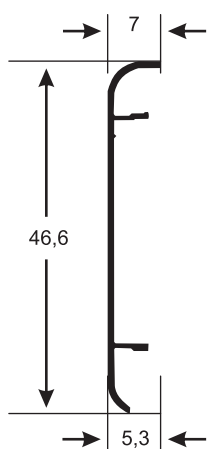

## ES - 030

3,390 kg / br

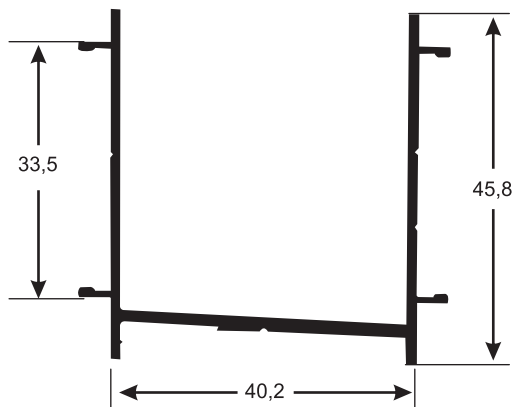

## ES - 032

3,020 kg / br

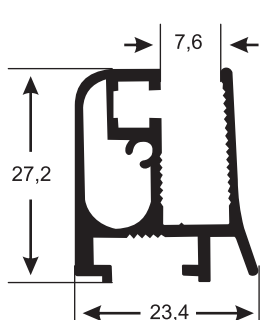

## ES - 033

6,025 kg / br

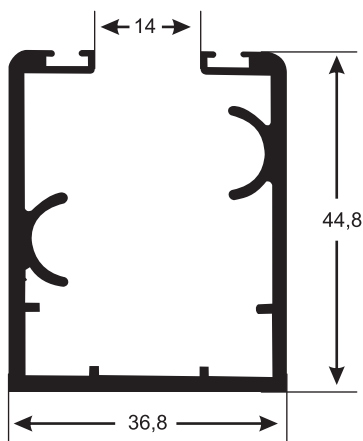

## ES - 034

3,065 kg / br

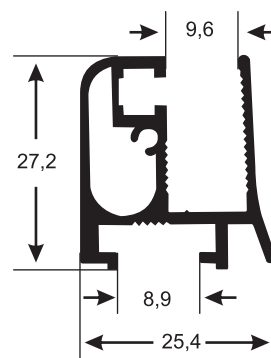

## ES - 035

7,245 kg / br

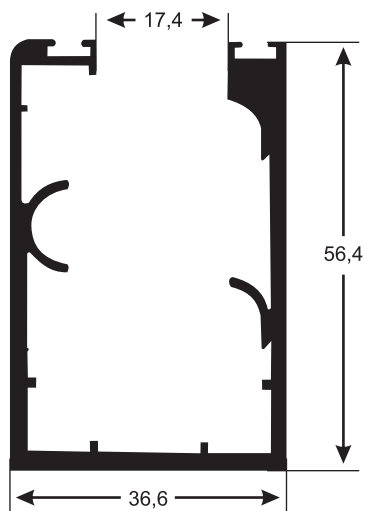

## ES - 040

3,355 kg / br

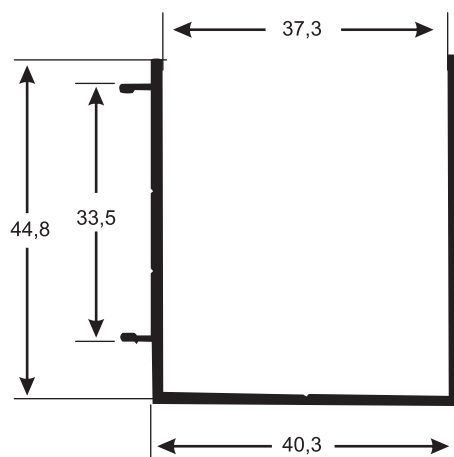



**FA-200**

11,860 kg /br

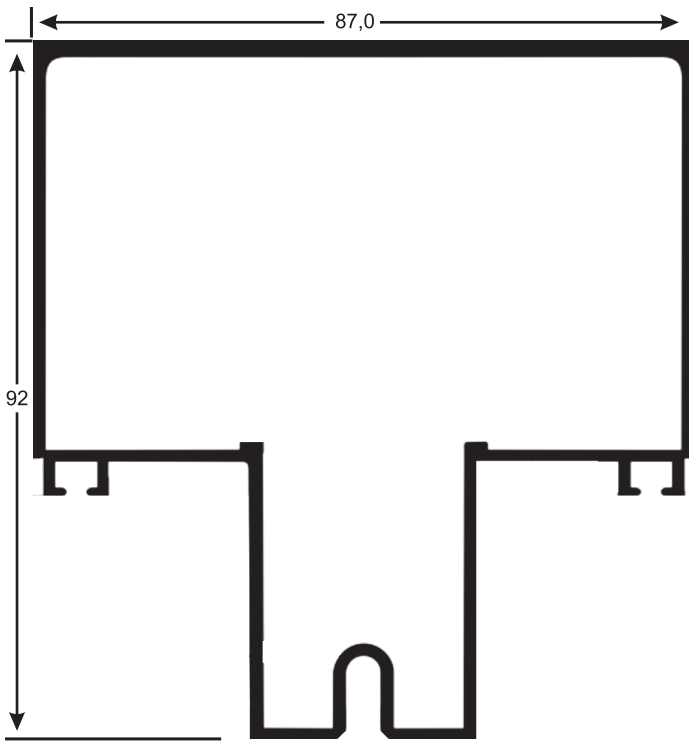

**FA-204**

6,353 kg /br

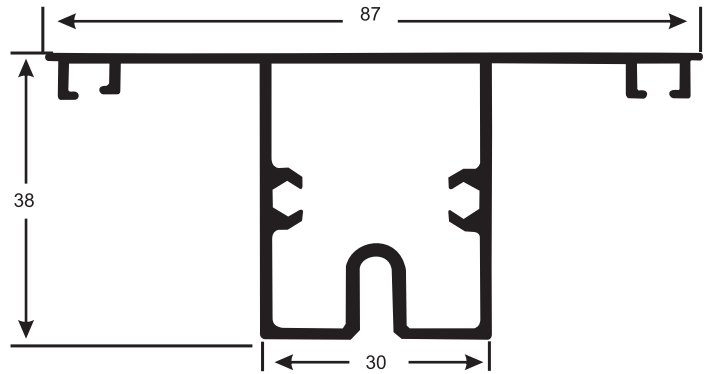

**FA-201**

9,400 kg /br

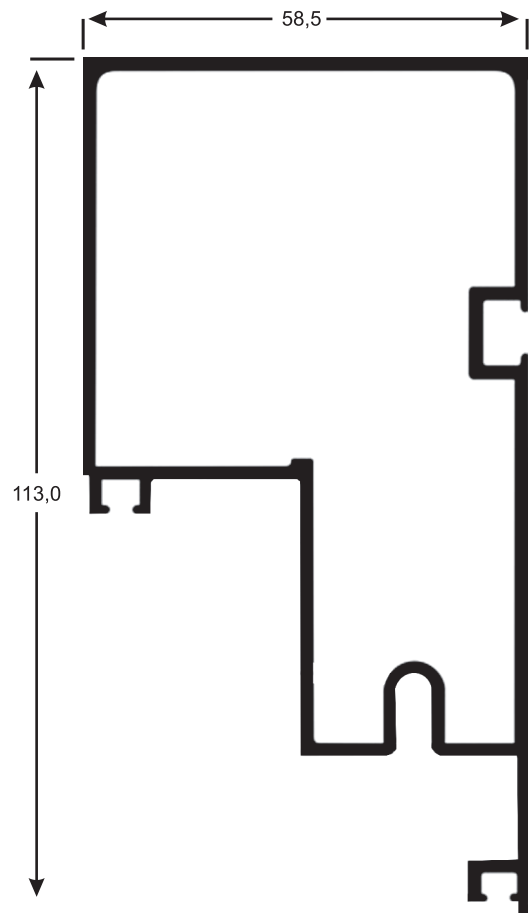

**FA-235**

8,300 kg /br

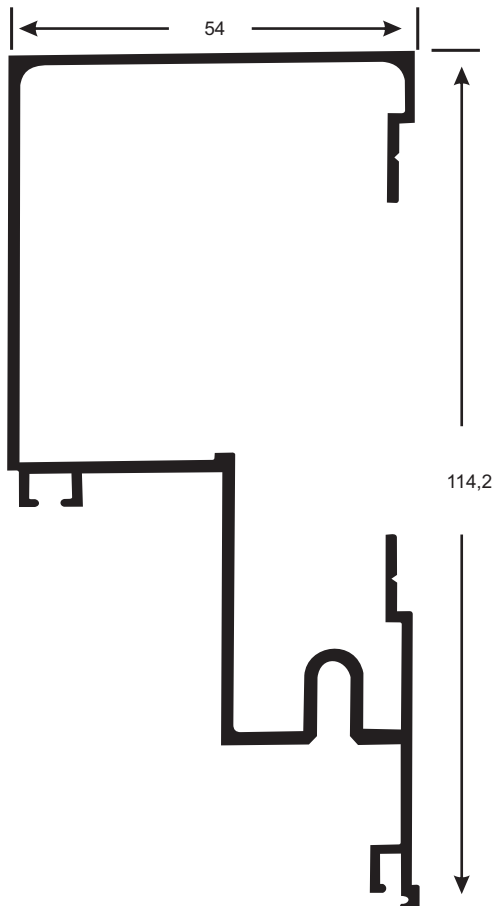



## FA-211

6,200 kg /br

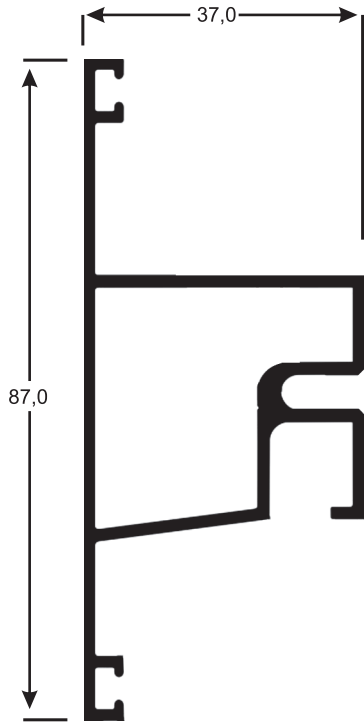

## FA-245

4,600 kg /br

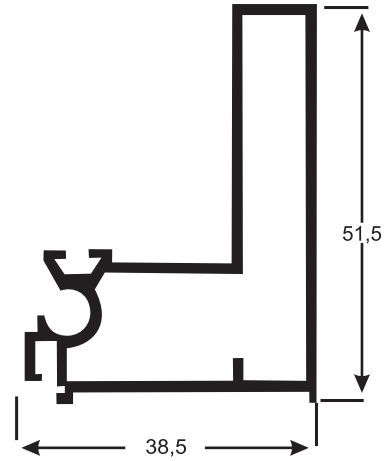

## FA-294

4,710 kg /br

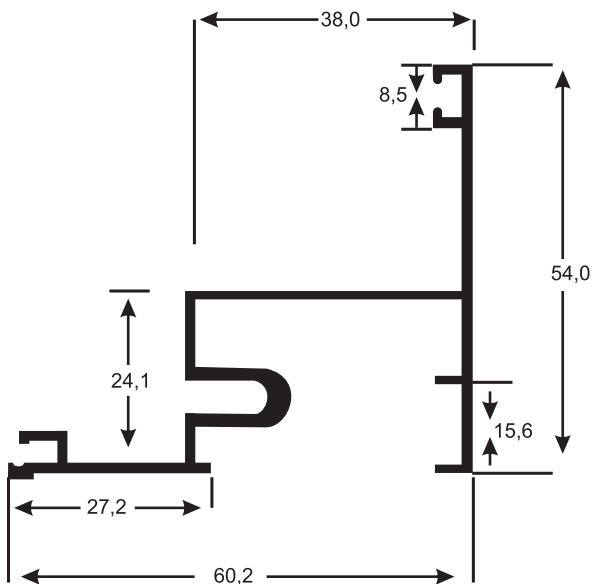

## FA-230

4,850 kg /br

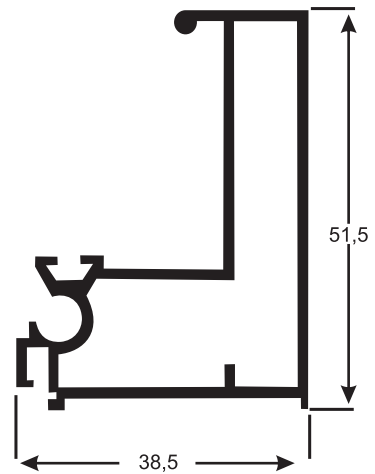



## FA-236

15,815 kg /br

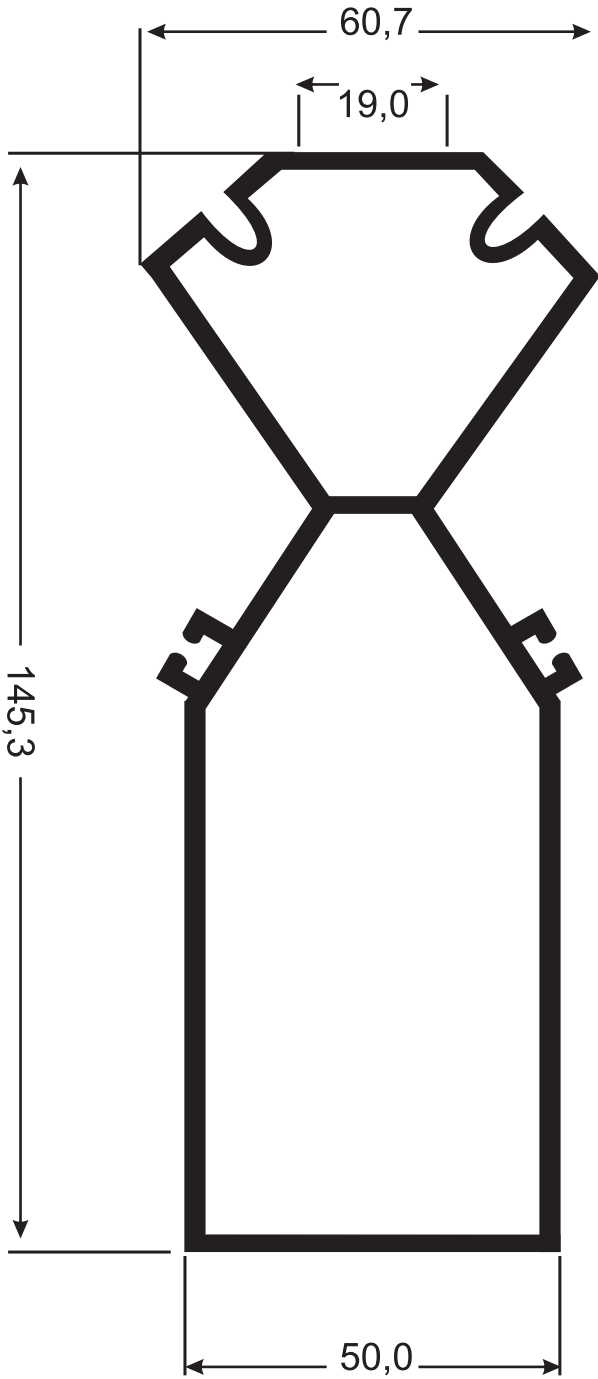

## FA-228

3,408 kg /br

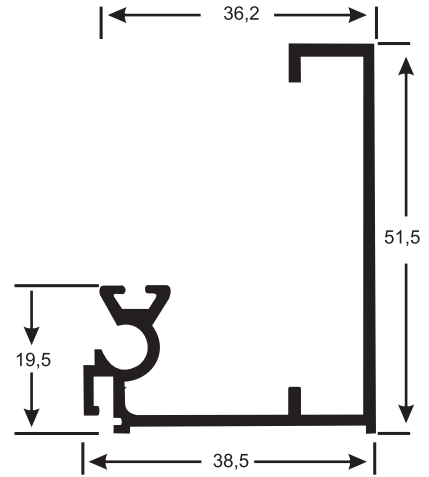

## FA-232

3,618 kg /br

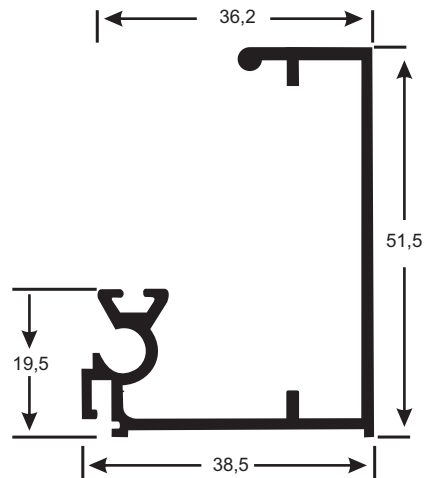



**FC-012**

6,100 kg /br

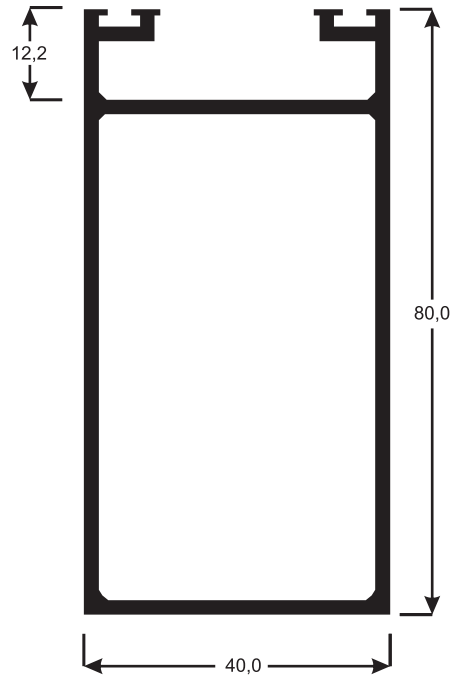

**FC-013**

1,500 kg /br

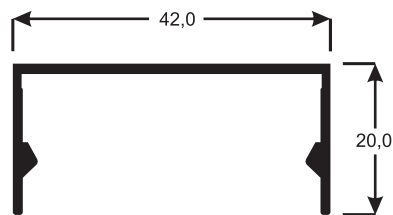

**FC-014**

2,200 kg /br

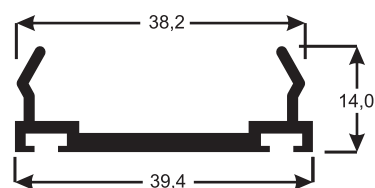



## BX-066

3,600 kg /br  
CALHA VIDRO 8MM/10MM

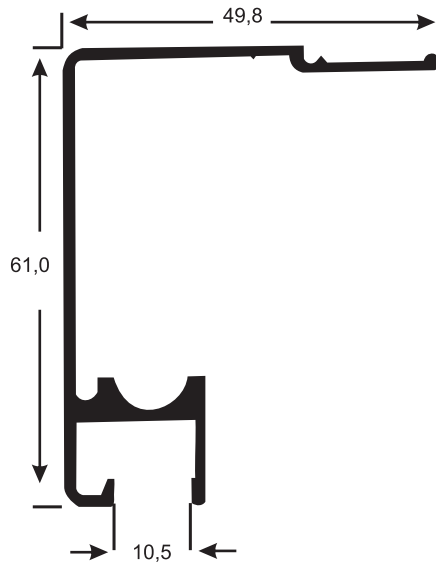

## BX-029

0,500kg /br  
CLICK PARA CALHA

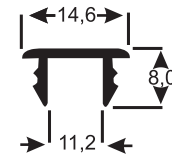

## PLK-023

1,200 kg /br

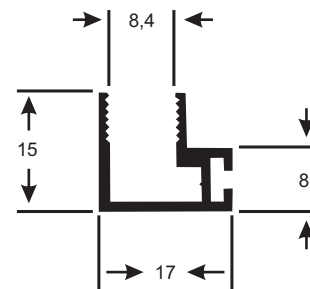

## BX-067

1,600 kg /br  
TAMPA DA CALHA BX-066 / BX-129

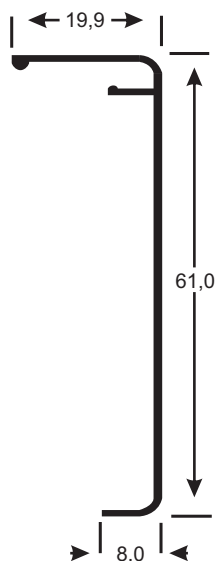

## PLK-037

0,900 kg /br  
ACABAMENTO INFERIOR 8MM

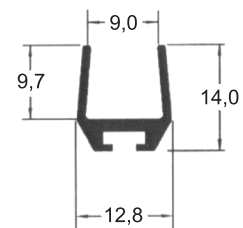



## PLK-525

3,180 kg /br

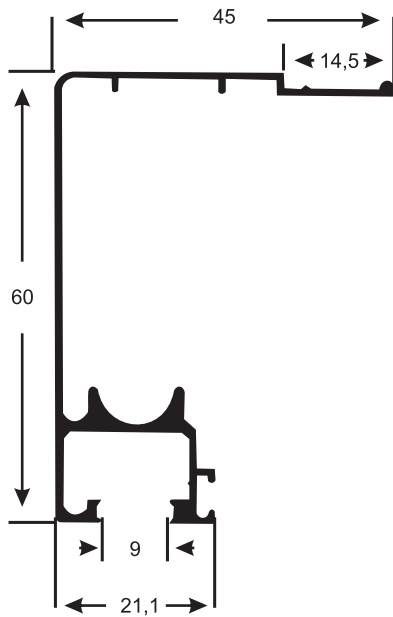

## PLK-058

1,460 kg /br

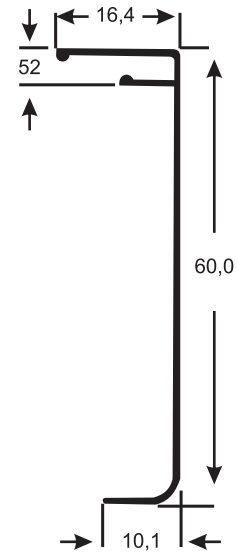

## PLK-043

0,500 kg /br

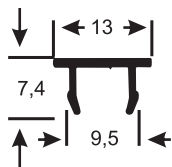

## PLK-007

1,000 kg /br

TRANSPASSE BAIXO PARA 8MM

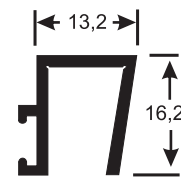

## PLK-046

0,910 kg /br

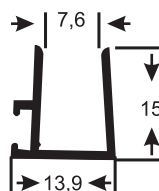



## **BX-041**

0,900 kg /br

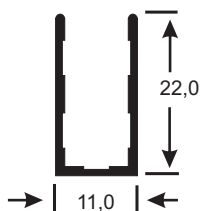

## **BX-107**

0,800 kg /br  
BATENTE DE VIDRO 8MM

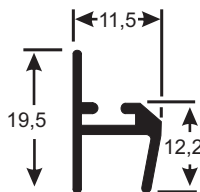

## **PLK-440 - 8/10mm**

1,250 kg /br

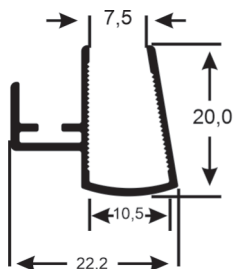

## **PLK- 038 - 8/10mm**

2,400 kg /br

Trilho inferior

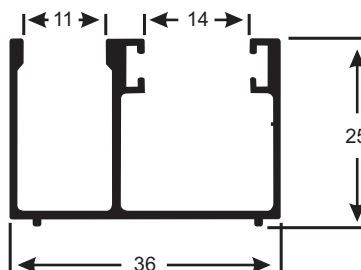

## **BX-164**

2,100 kg /br  
TRILHO INFERIOR 8MM

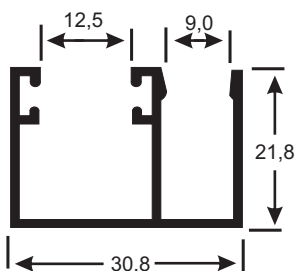

## **PLK-047**

1,400 kg /br  
BATENTE DE VIDRO 8MM

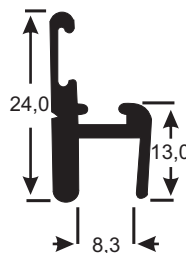



## PLK-053

7,600 kg /br  
CALHA PESADA VIDRO 10MM

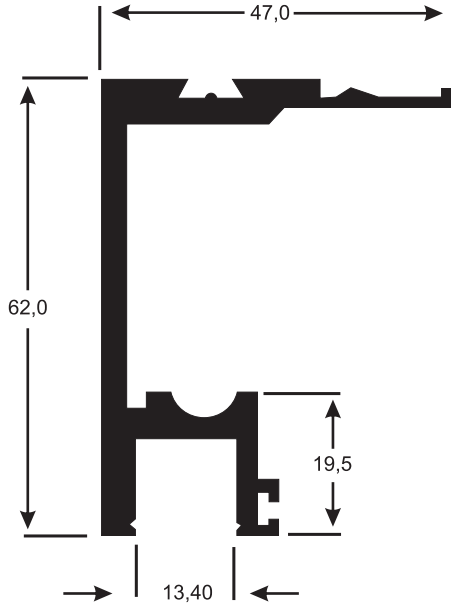

## BX-129

4,100 kg /br  
TRILHO SUPERIOR VIDRO 10MM

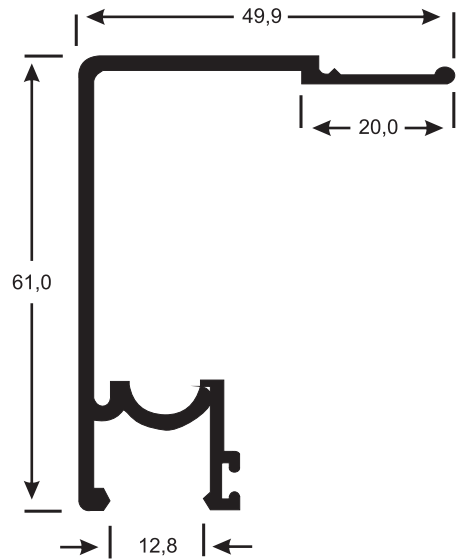

## BX-128

1,800 kg /br  
TAMPA DA CALHA P/ BX-066 / BX-129

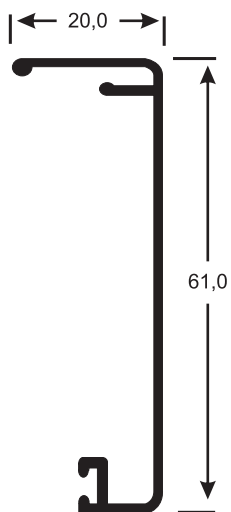

## BX-127

0,600 kg /br  
CLICK PARA CALHA 10MM

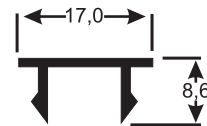



## PLK-012

3,700 kg /br

TRILHO INFERIOR DUAS MÓVEL ABAS DESIGUAIS

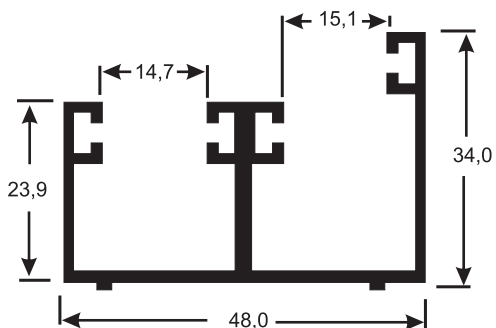

## PLK-017

1,600 kg /br

BATENTE DE VIDRO 10MM

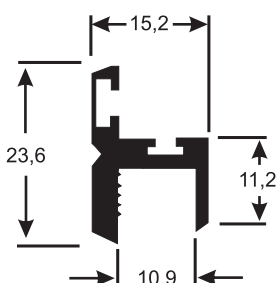

## PLK-034

1,340 kg /br

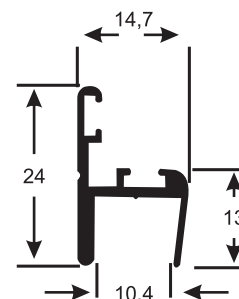

## PLK-518

2,738 kg /br

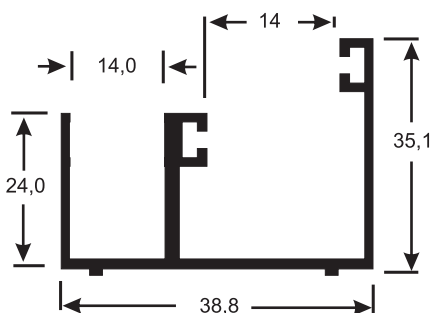

## PLK-029

0,900 kg /br

BATENTE CADEIRINHA 10MM

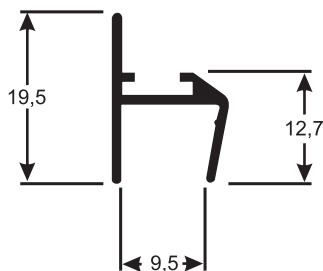

## CX-175 = CX-125

5,185 kg /br

TRILHO SUPERIOR DUPLO LEVE PARA 10MM

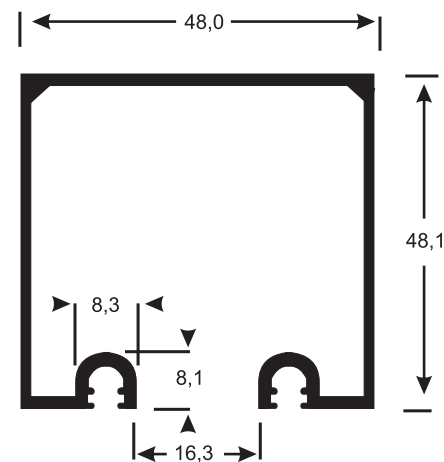

## PLK-057

2,100 kg /br

TRILHO INFERIOR 1 MÓVEL, 1 FIXA 10MM

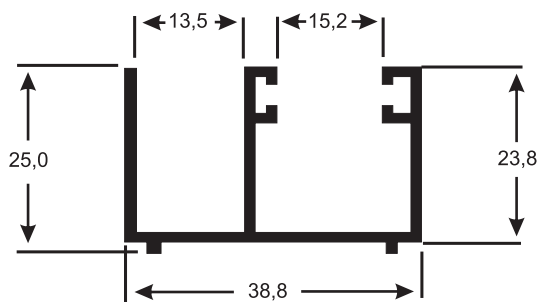

## BX-125

2,900 kg /br

TRILHO INFERIOR DUAS MÓVEL

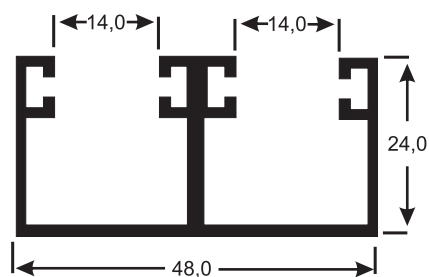



## CX-146

7,000 kg /br  
TRILHO SUPERIOR DUPLO PESADO PARA 10MM

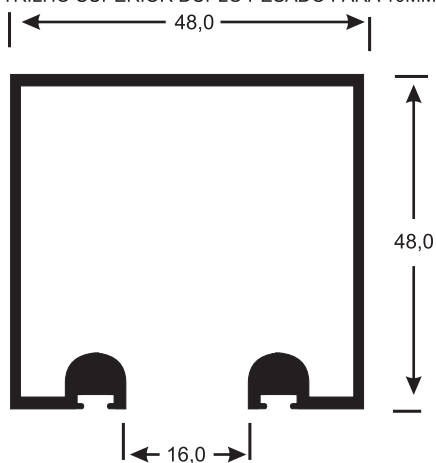

## U-1108

1,900 kg /br  
TRILHO INFERIOR 1 MOVEL

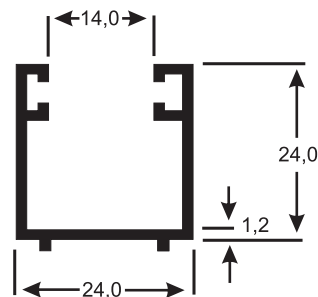

## BX-030

1,350 kg /br  
TRANSPASSE ALTO 10MM

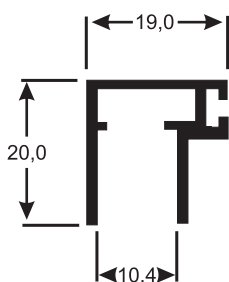

## PLK-014

0,960 kg /br  
TRANSPASSE BAIXO 10MM

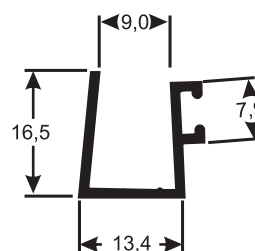

## BX-099

1,400 kg /br  
CANTONEIRA C/BAGUETE 10MM

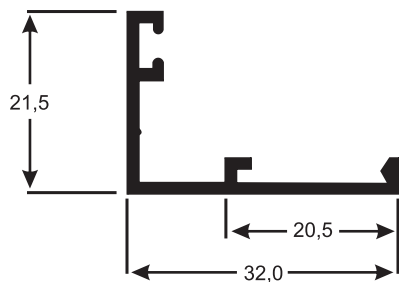

## BX-100

0,950 kg /br  
BÁGUETE P/ CANTONEIRA 10MM

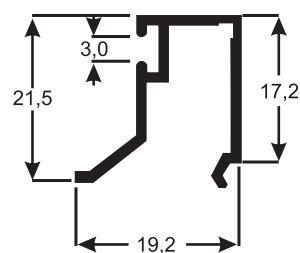



## PLK-516

11,750 kg /br

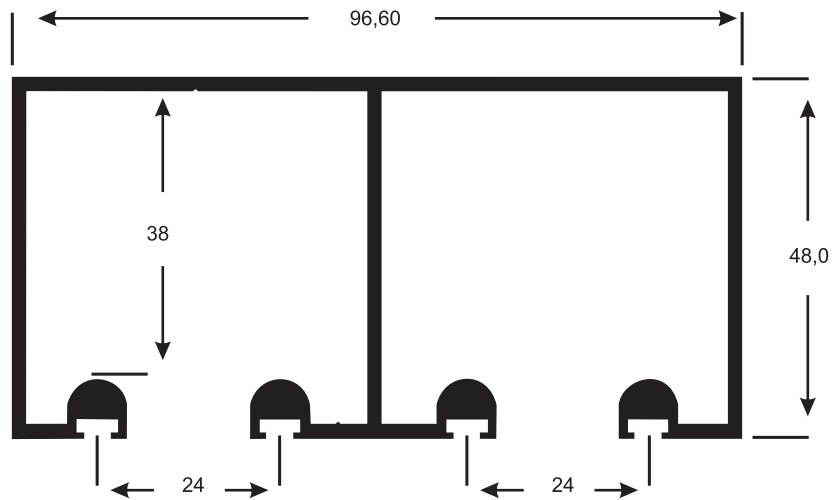

## PLK-541

5,850 kg /br

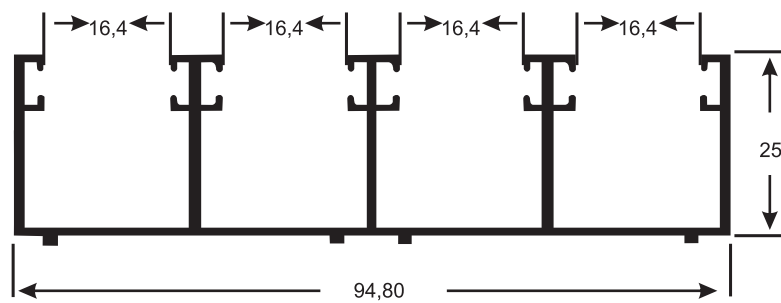



## **BX-098**

0,850 kg /br

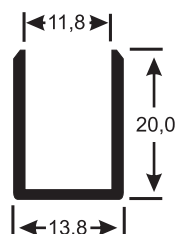

## **PEU-315**

1,000 kg /br

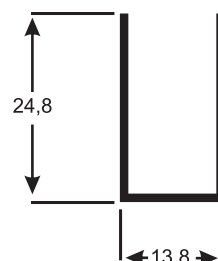

## **PLK-025**

2,100 kg /br

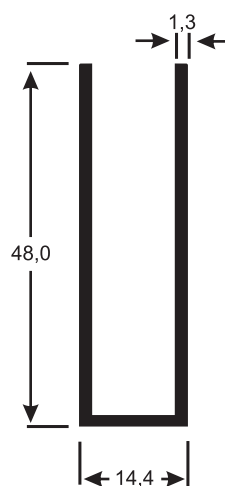

## **PEU-028**

0,900 kg /br

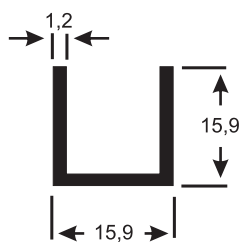

## **PEU-329**

1,300 kg /br

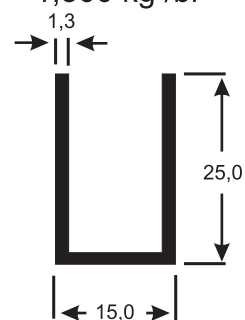



### CAT-001

0,600 kg /br



### CAT-005

0,800kg /br



### CAT-007

0,900 kg /br



### CAT-016

1,300 kg /br

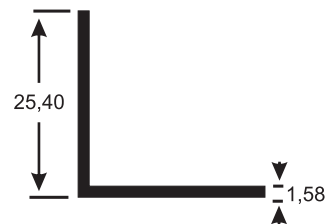

### CAT-026

3,800 kg /br

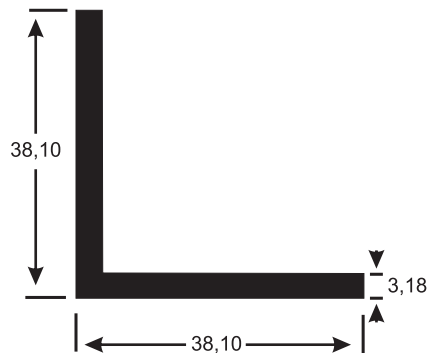

### CAT-029

5,200 kg /br

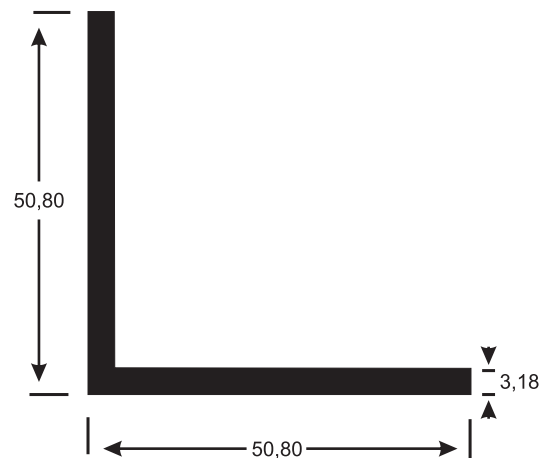



## TUG-022

7,668 kg /br

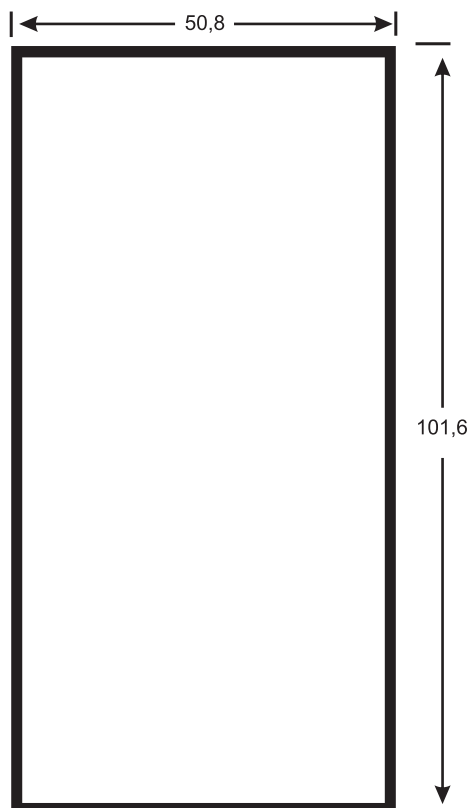

## TUG-022L

6,400 kg /br

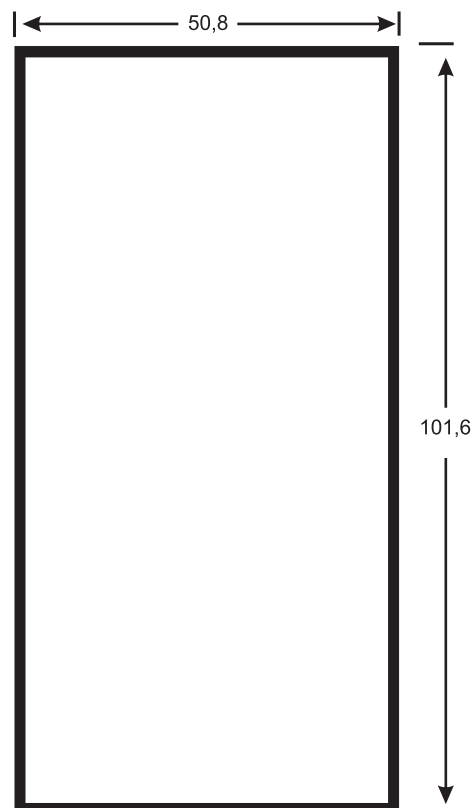

## TUG-014

4,390 kg /br





## TUQ-060

11,700 kg /br

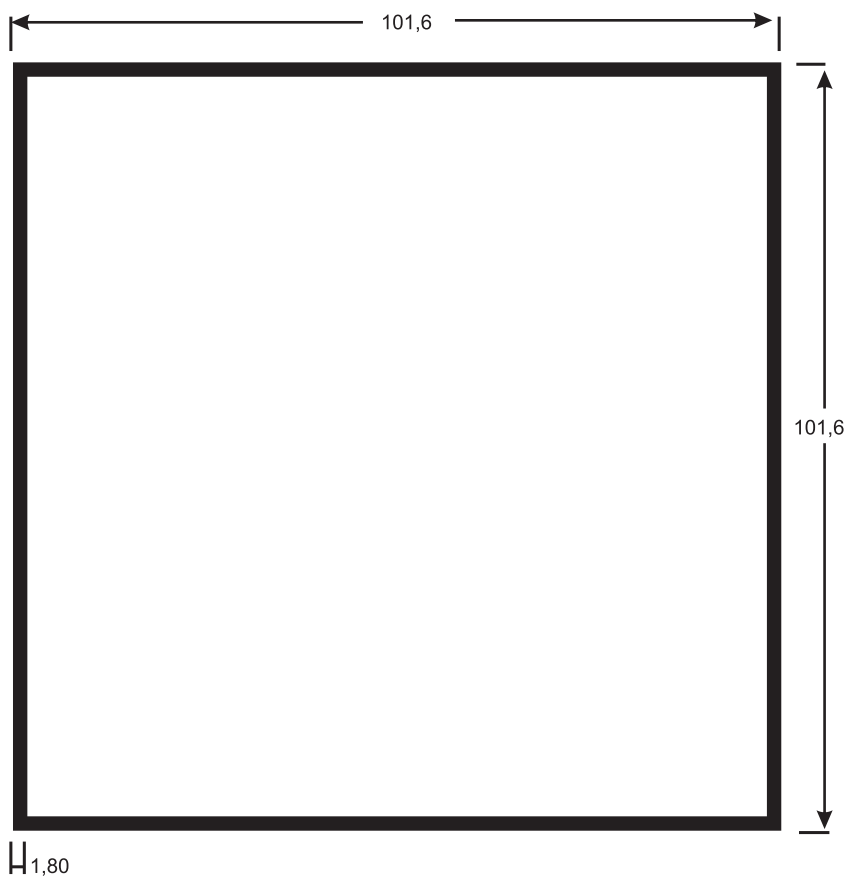

## TUQ-061

7,300 kg /br

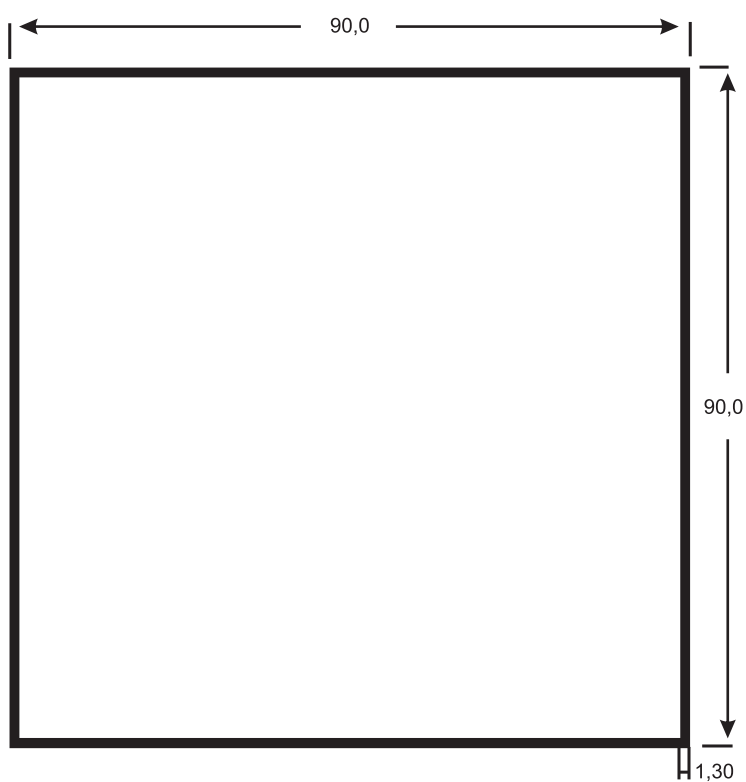



## TUQ-051L

3,900 kg /br

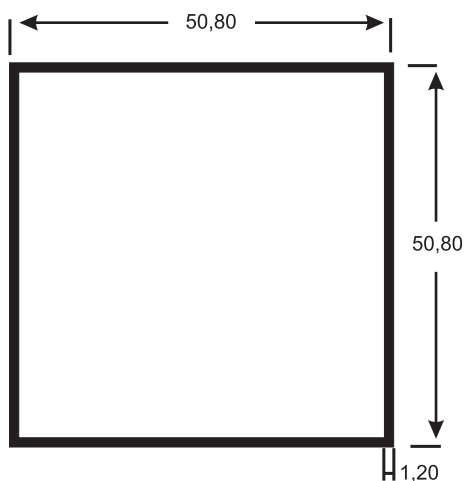

## TUQ-014

3,800 kg /br

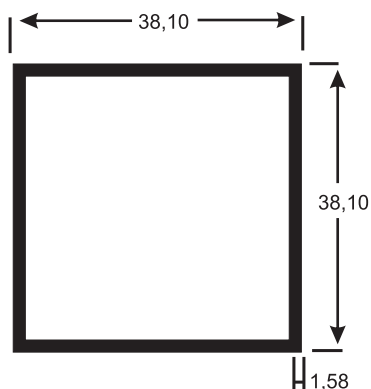

## TUQ-015

3,000 kg /br

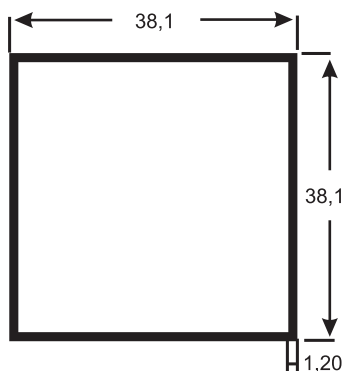

## TUQ-014L

1,965 kg /br

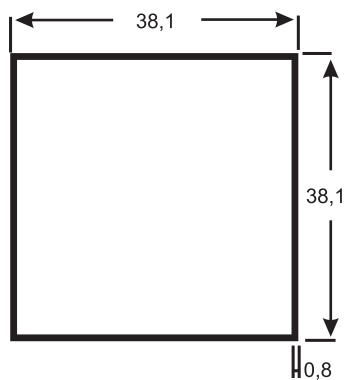

## TUQ-059

2,670 kg /br

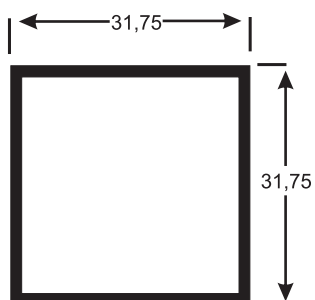

## TUQ-009L

1,450 kg /br

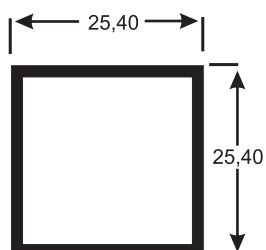



### U-990 = DS 152

3,600 kg /br  
TRILHO RETO

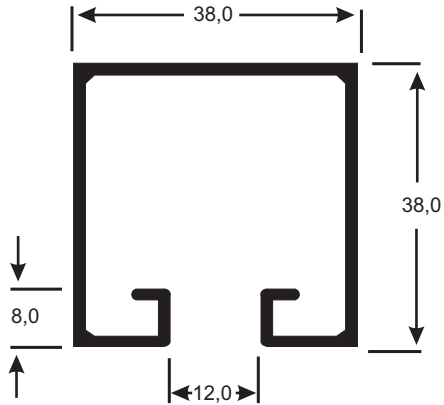

### U-1098 = DS 266

3,000 kg /br  
TRILHO CONCAVO

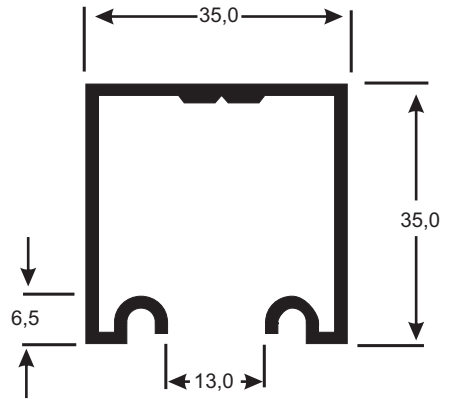

### U-1098L = DS 266

2.560 kg /br  
TRILHO CONCAVO

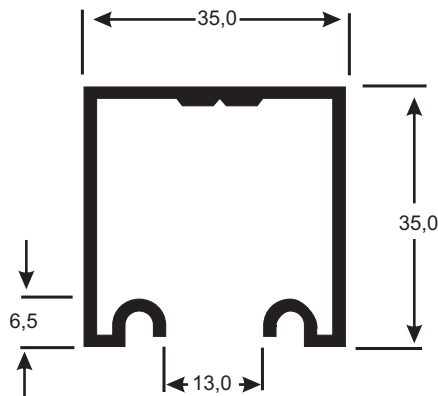

### CX-175L = CX-125

4,350 kg /br  
TRILHO SUPERIOR DUPLO LEVE PARA 10MM

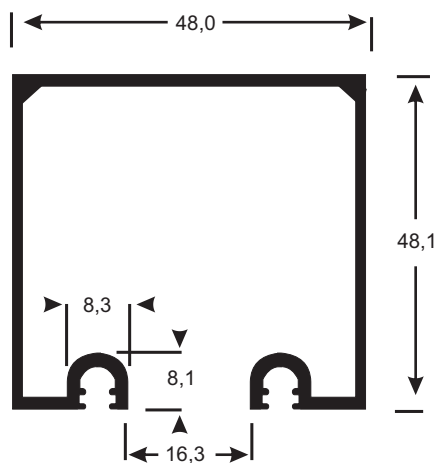

### CX-146

7,000 kg /br  
TRILHO SUPERIOR DUPLO PESADO PARA 10MM

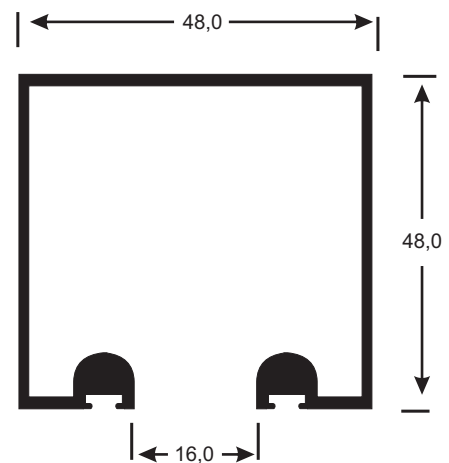



**D-069 = PC 003**

5,000 kg /br

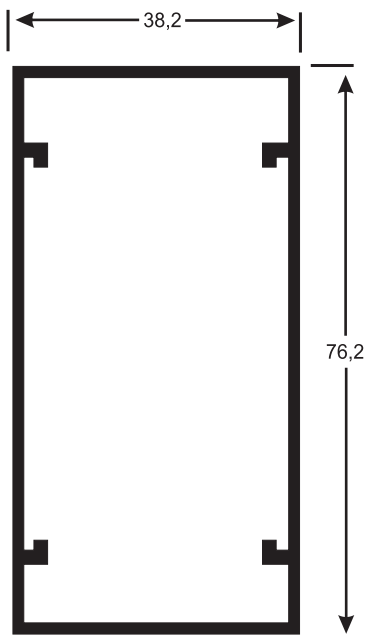

**D-078 = PC-004**

3,900 kg /br

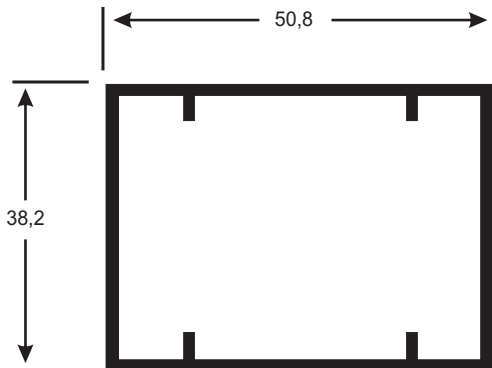

**PDV - 079**

0,890 kg /br

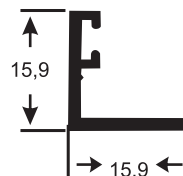

**Y-107**

1,400kg /br

GUIA DO PORTÃO DESLIZANTE

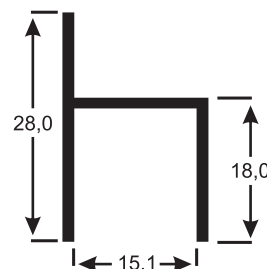

**20 142**

2,100 kg /br  
GUIA

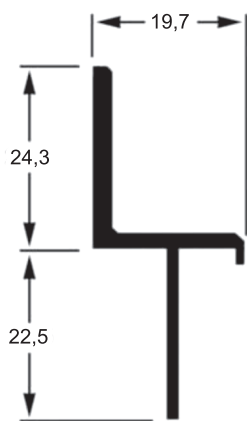

**PEU-047**

2,300 kg /br

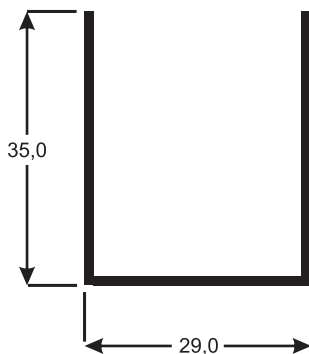

**E-364 = PC-006**

2,500 kg /br

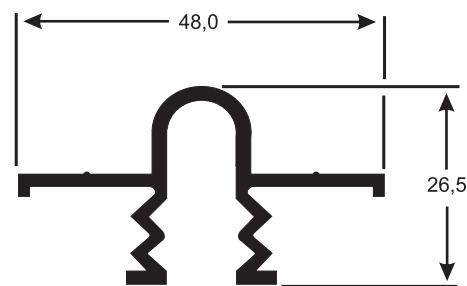

**D-079L = PC-002**

2,600 kg /br

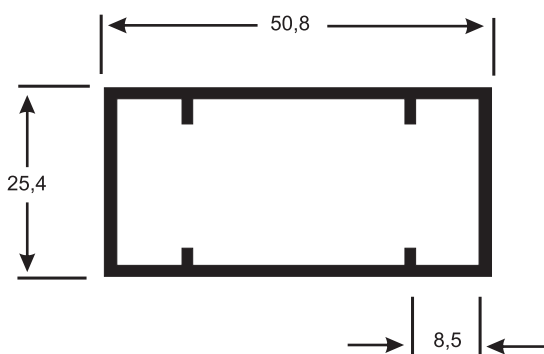

**D-079**

3,020 kg /br

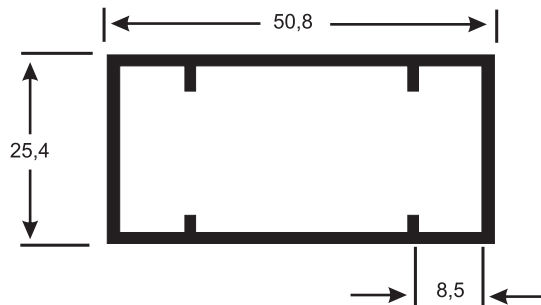



## PC-010

5,900 kg /br

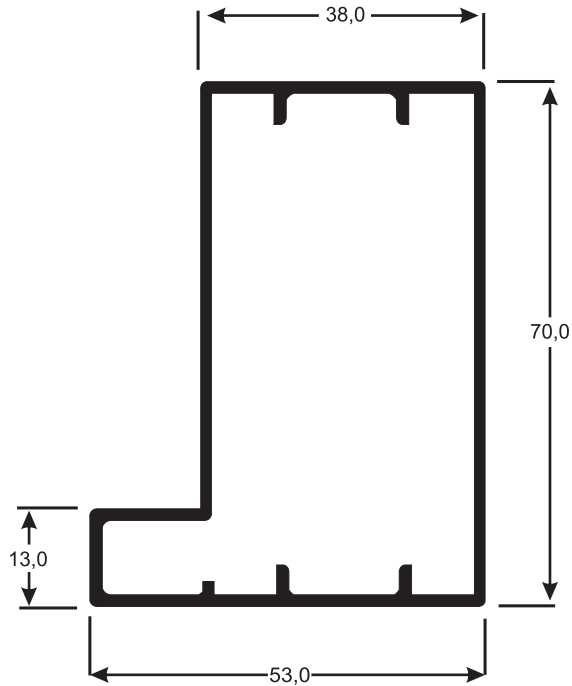

## LB-004

3,800 kg /br

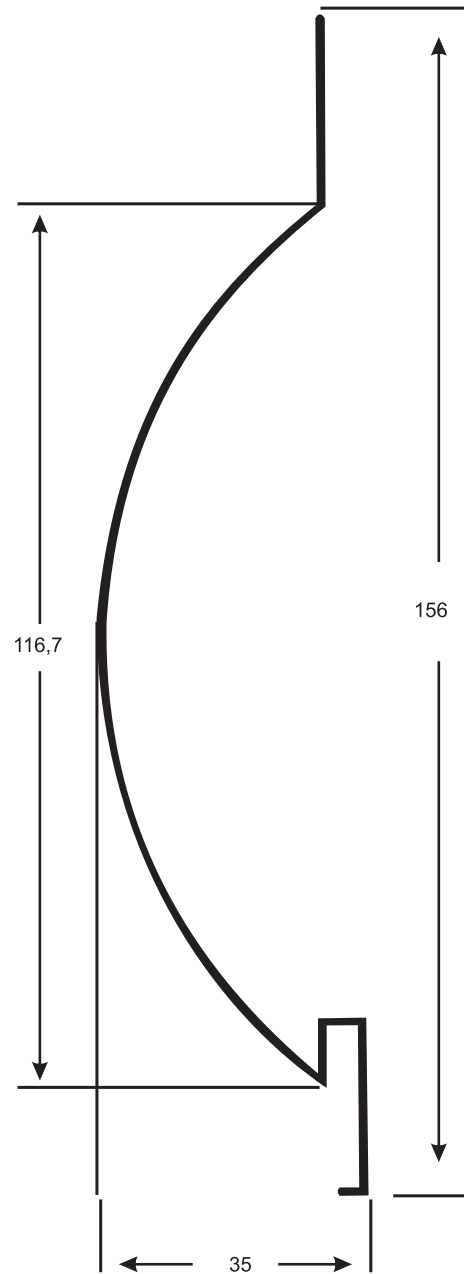

## PC-010L

4,550 kg /br

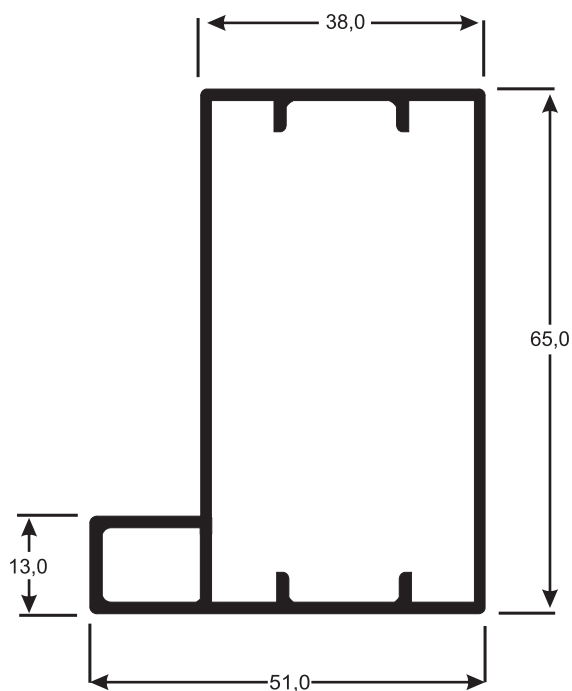



**Y-335**

3,800 kg /br

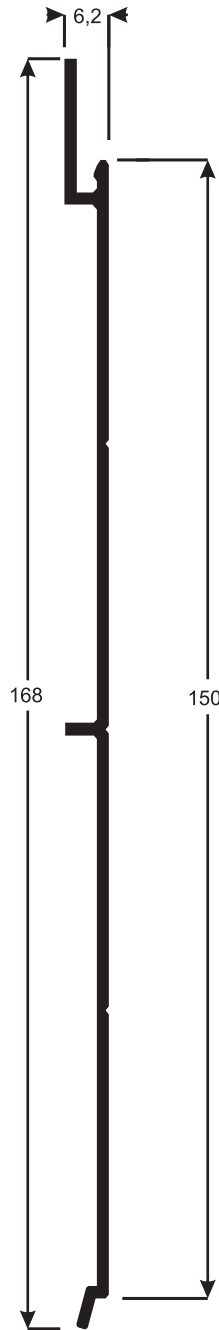

**Y-429 = LB-050**

3,800 kg /br

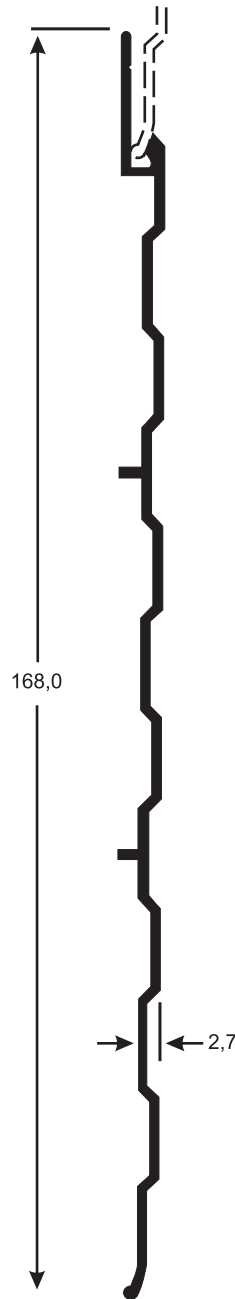

**LB-043**

6,130 kg /br

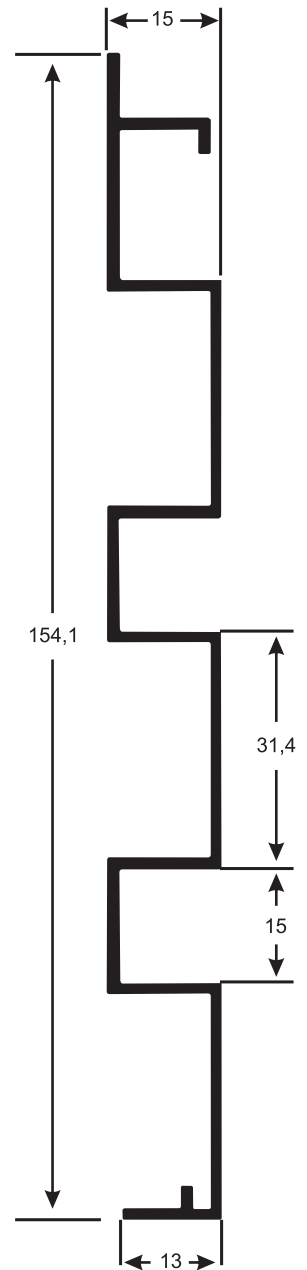

**LB-061**

4,600 kg /br

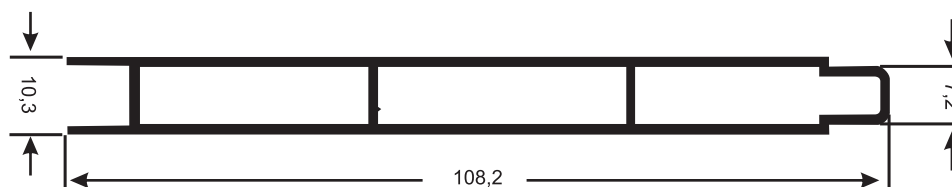



## D-107

3,950 kg /br  
TAMPA DO TRAVESSÃO

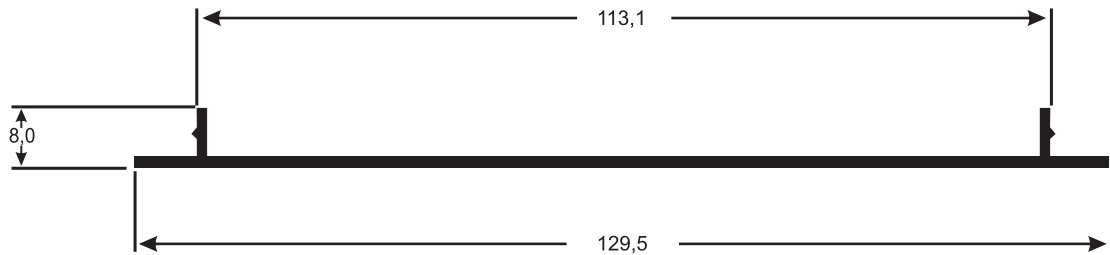

## D-108

9,650 kg /br  
TRAVESSA DAS COLUNAS  
PORTÃO BASCULANTE

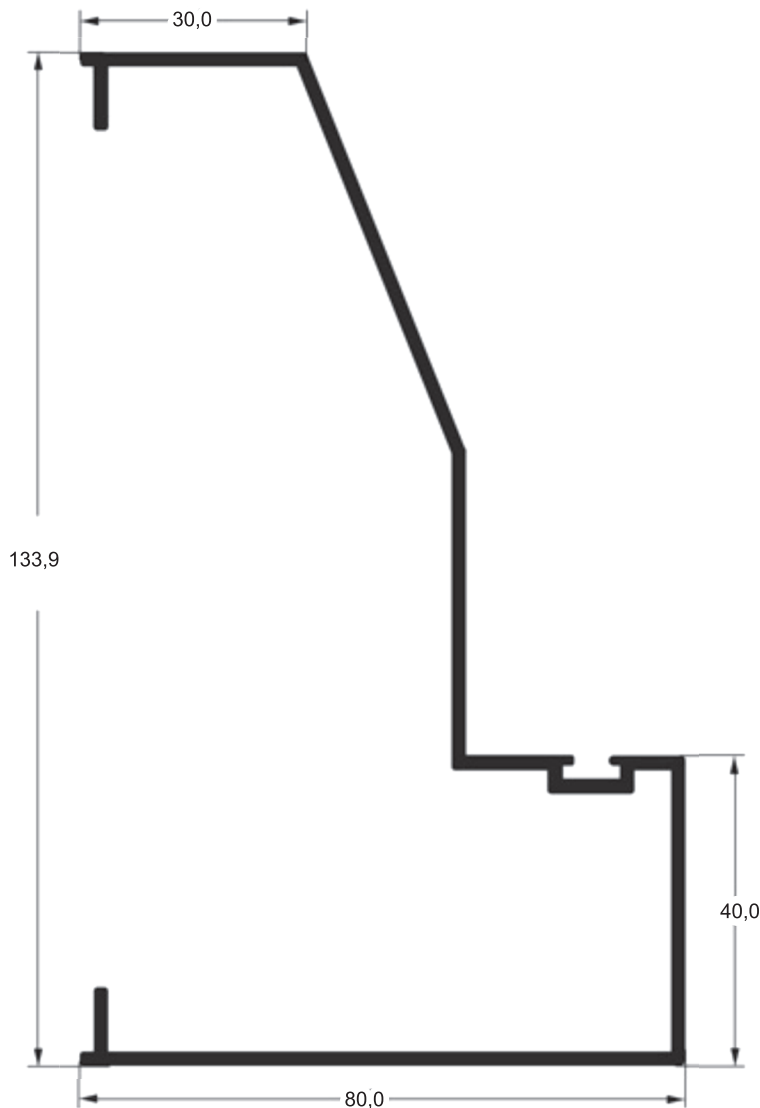

## TUR-070

3,028 kg /br

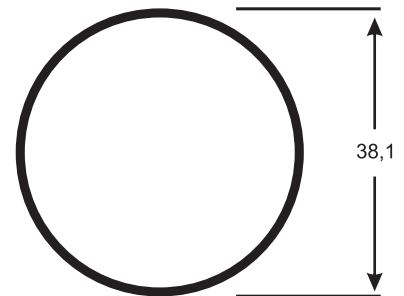



## D-084

17,100 kg /br

COLUNA DO PORTÃO BASCULANTE/ELEVAÇÃO

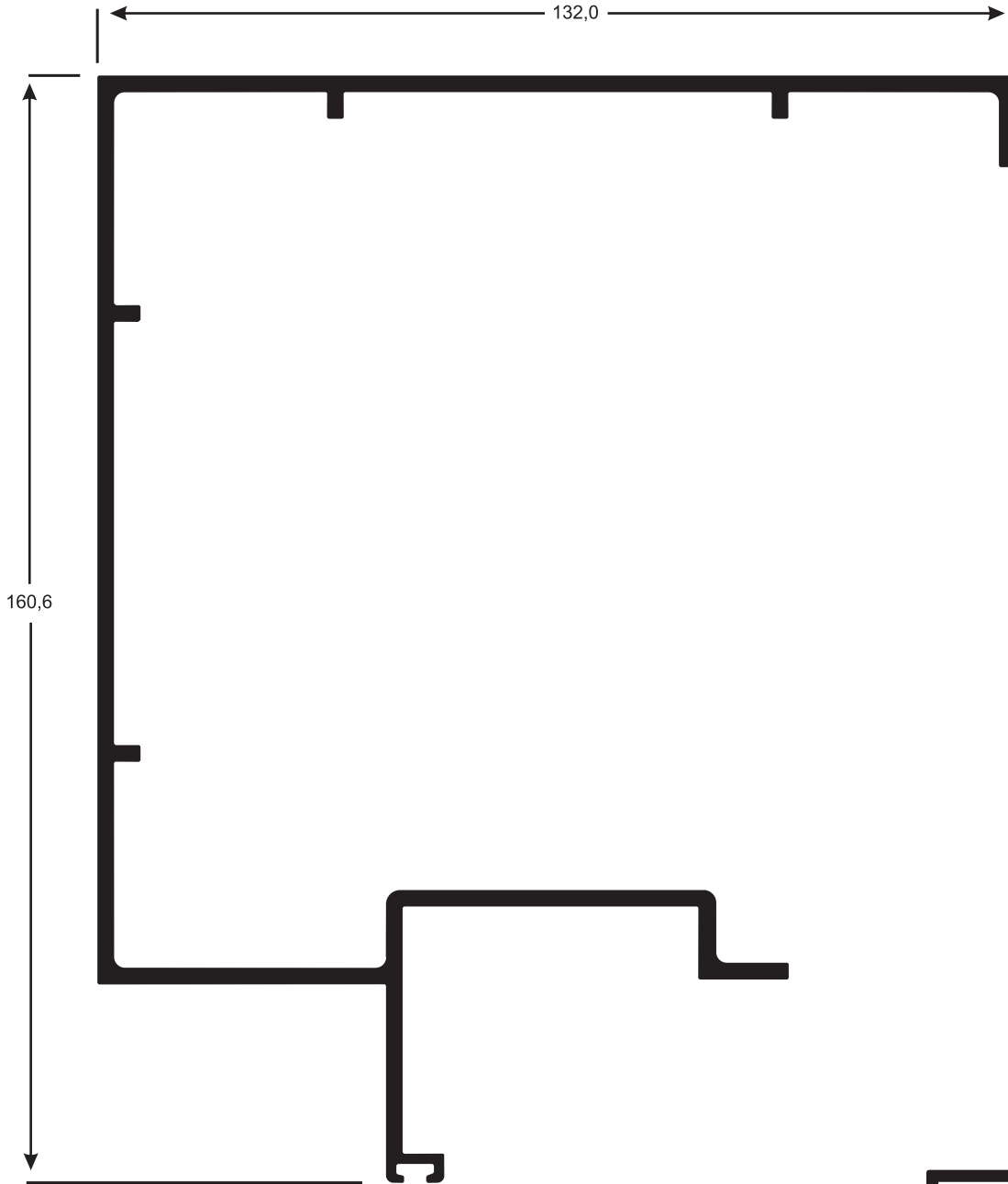

## D-083

7,100 kg /br

TAMPA DA COLUNA DO PORTÃO

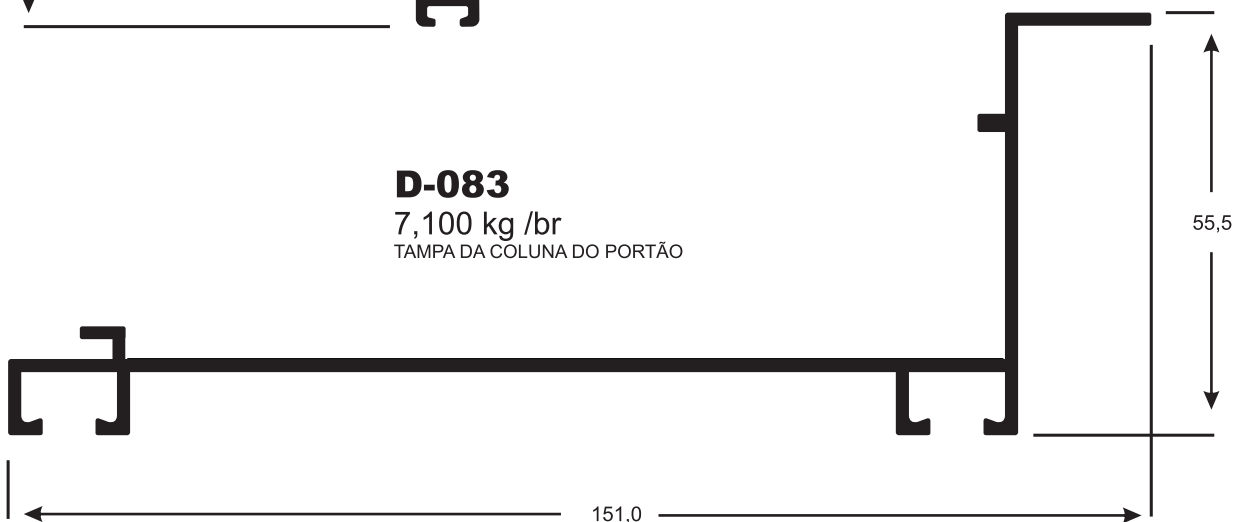



**D-055 = CG 012**

2,870 kg /br

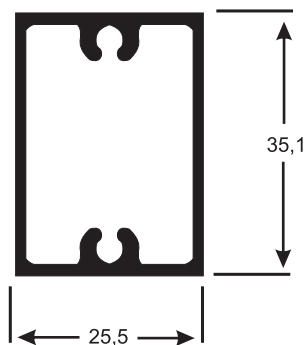

**D-082 = CG 021**

2,000 kg /br

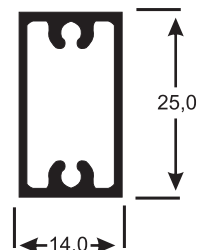

**CX-071**

4,200 kg /br

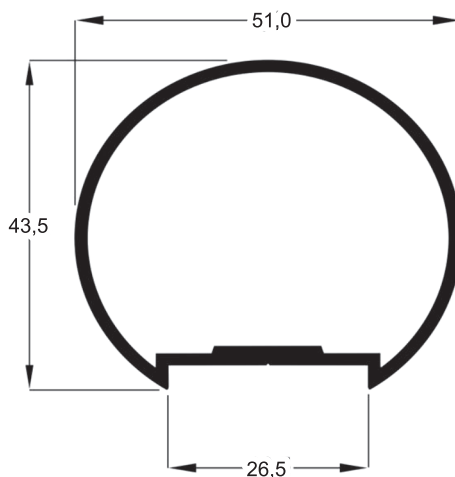

**CG-079**

2,000 kg /br

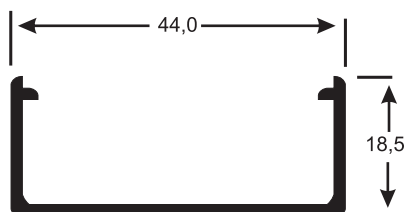

**CG-078**

2,500 kg /br

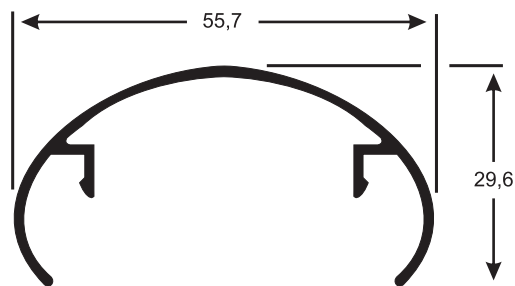



## CG-074

1,600 kg /br

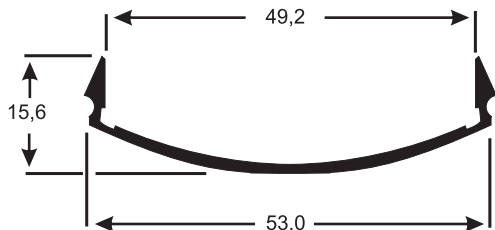

## CG-075

3,100 kg /br

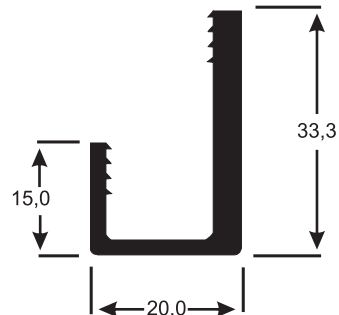

## CG-077

5,100 kg /br

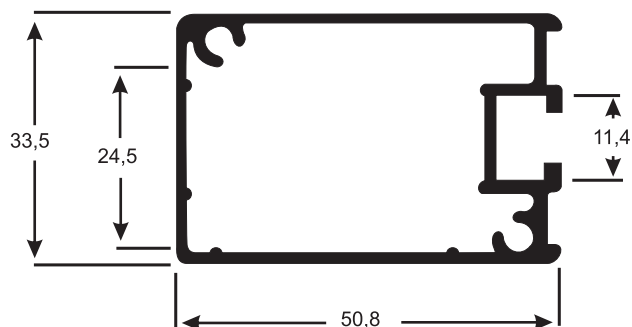

## CG-083

8,400 kg /br

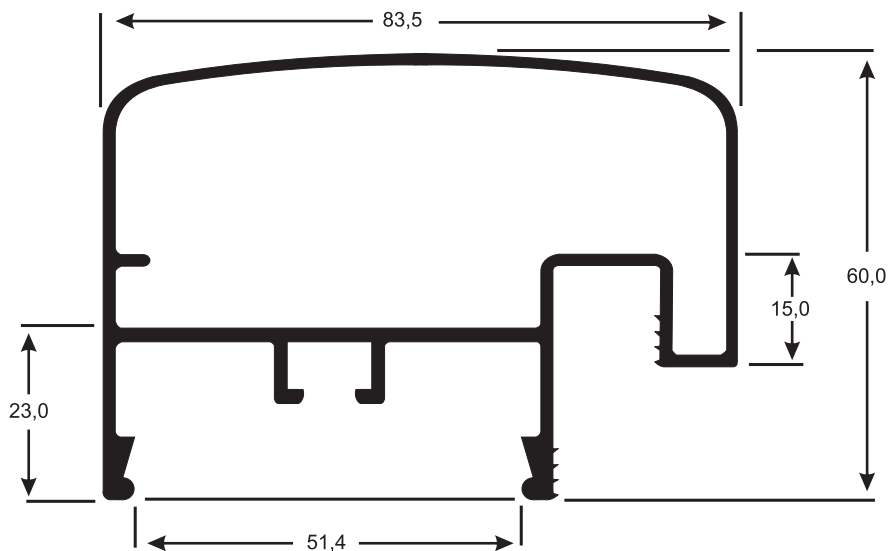



### BK-005

1,000 kg /br

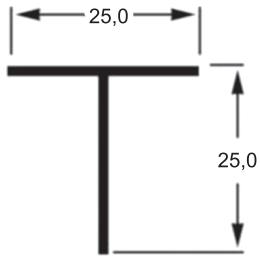

### TUR-039

1,300 kg /br

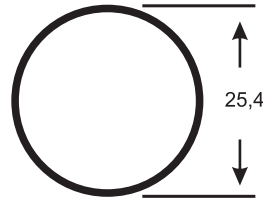

### BK-022

0,900 kg /br

CABIDEIRO

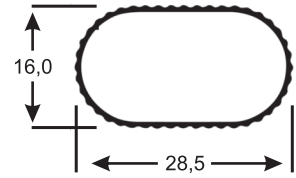

### BK-545L

1,740 kg /br

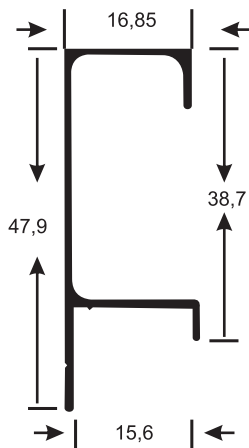

### BK-546L

1,900 kg /br

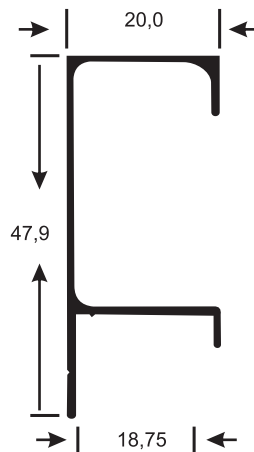

### BK-544

1,300 kg /br

PUXADOR GAVETA

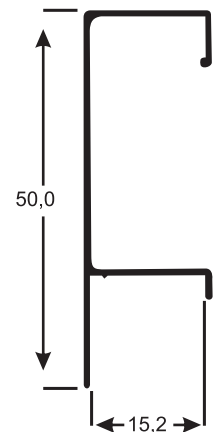

### BK-036

2,000 kg /br

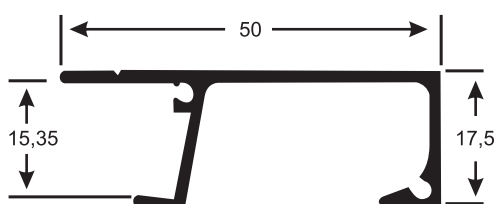

### BK-035

2,142 kg /br

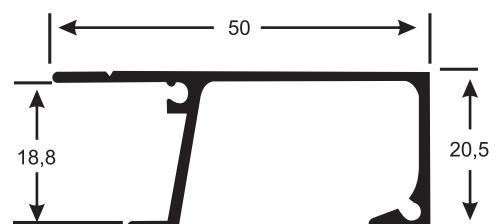



**BK-432**

2,400 kg /br  
PUXADOR DA GAVETA

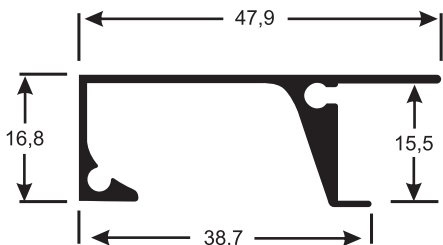

**BK-431**

2,750 kg /br  
PUXADOR DA GAVETA

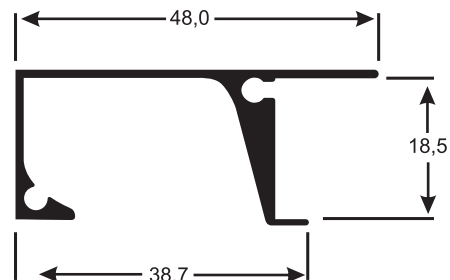

**BK-506**

1,100 kg /br

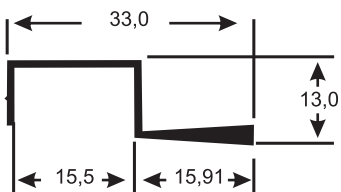

**BK-503**

1,400 kg /br  
PUXADOR GAVETA  
PUXADOR DA PORTA

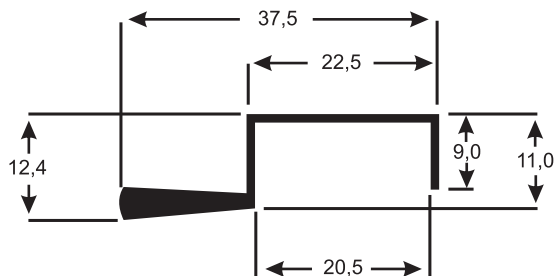

**BK-183**

1,550 kg /br

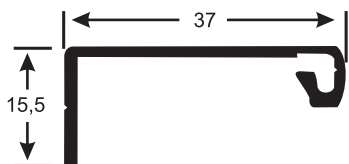

**BK-408**

1,900 kg /br  
PUXADOR DA PORTA  
PUXADOR DA GAVETA

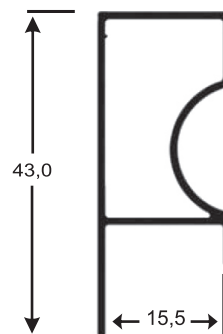

**BK-516**

2,000 kg /br  
TRILHO SUPERIOR

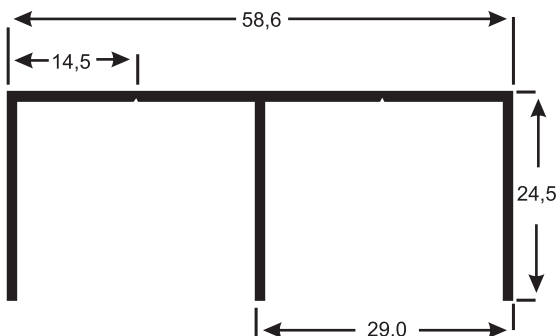

**BK-529**

0,500 kg /br  
TRILHO INFERIOR 1 PORTA

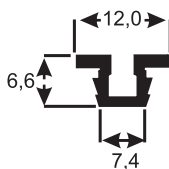

**BK-500**

1,285 kg /br  
TRILHO INFERIOR PESADO

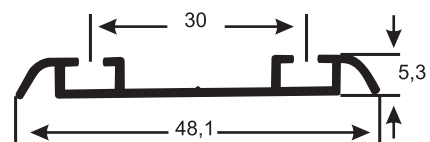



## BK-498

3,600 kg /br  
MONTANTE DA PORTA

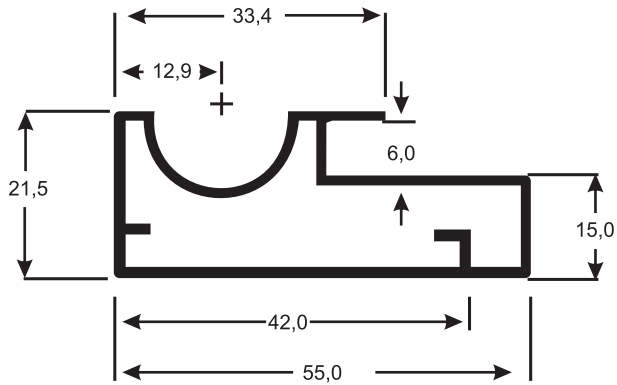

## BK-497

2,600 kg /br  
MONTANTE DA PORTA

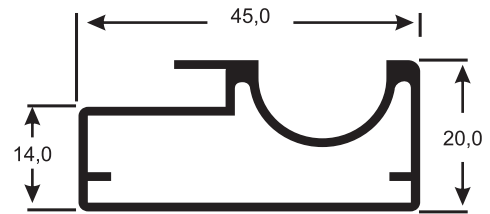

## BK-536

2,400 kg /br  
MONTANTE DA PORTA

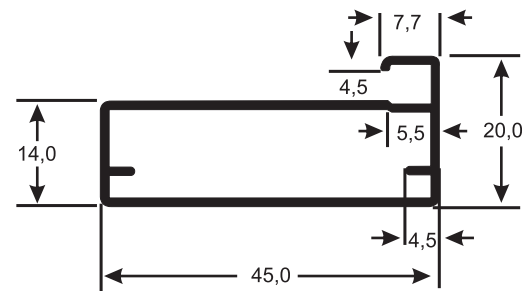

## BK-615

3,715 kg /br

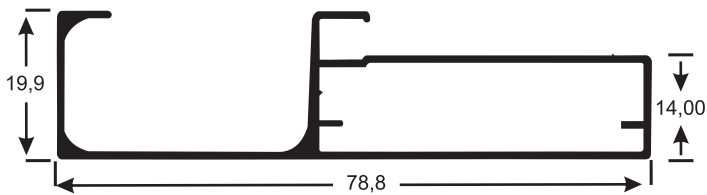

## BK-563

2,400 kg /br  
MONTANTE DA PORTA

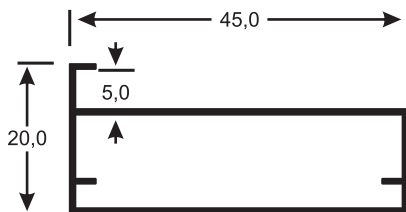

## BK-578

2,600 kg /br  
MONTANTE DA PORTA

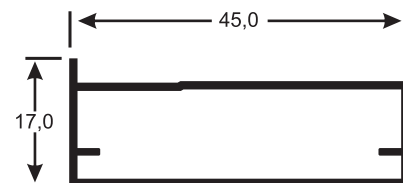

## BK-072

0,670 kg /br

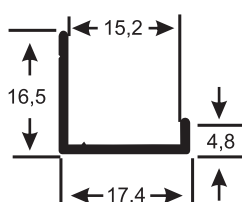

## BK-073

0,770 kg /br

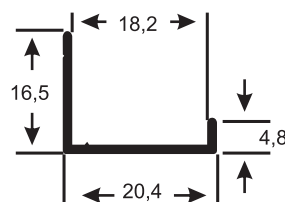

## PEU-015

1,200 kg /br

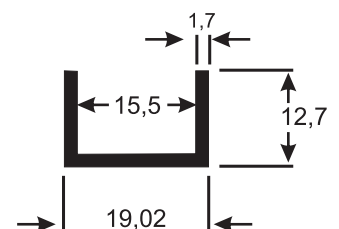



**BK 552**  
1,100 kg /br

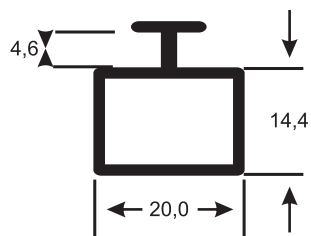

**BK-263**  
1,250 kg /br  
TRAVESSA

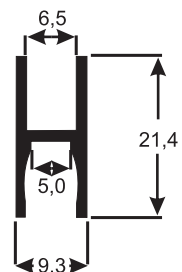



## CX-170

1,900 kg /br  
TRAVESSA TELA

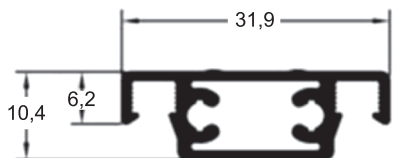

## CX-171

1,300 kg /br  
TELA MOSQUITEIRA

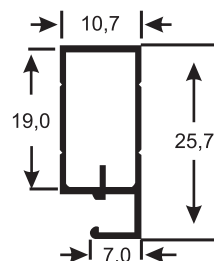

## BK-005

1,000 kg /br

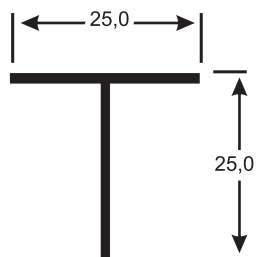



**ALUCRIU**  
PERFIS E ACESSÓRIOS



[www.alucriu.com.br](http://www.alucriu.com.br)

Fone: ☎ (48) 99633-3322 | ☎ (48) 3045-6959

Rua Giacomo Sônego Neto, 331 - CEP 88804-440 - Criciúma - Santa Catarina